

Air Spring Technologies



ITT

ENGINEERED FOR LIFE



Applications:

- Material Handling Industry
- Lumber Industry
- Aluminum Can Recycling
- Container Manufacturers
- Paper Industry
- Press Manufacturing
- Vibrating Equipment & Conveyers
- Shaker Screens
- Steel Manufacturing Equipment
- Automotive Related (Plate Glass)



Table of Contents

Product Selection

Company Overview	2	General
Global Service & Support	3	
Air Spring Products		
Introduction		Introduction
Air Springs Overview	4	
Sizing Software	5	
Advantages of Enidine Air Springs.....	6	
General Information	7	
Application Versatility	8	
Installation and Operating Instructions	9	
Air Spring Sizing		Sizing
Air Spring for Actuation	10	
Air Spring for Vibration Isolation	11	
Selection Charts		Selection Charts
Single Convolute Type Air Springs	12	
Double Convolute Type Air Springs	14	
Triple Convolute Type Air Springs.....	16	
Sleeve and Rolling Lobe Type Air Springs.....	18	
Bead Ring Style Air Springs		Bead Ring Selection Charts
Overview	20	
Applications and Other Uses	21	
Single Convolute.....	22	
Double Convolute	27	
Triple Convolute	33	
Notes.....	38	

Need Assistance? Enidine is ready to answer your questions, feel free to contact us at:

Phone: Toll Free - 1.800.852.8508
Direct - 1.716.662.1900

Fax: General - 1.716.662.1909
Industrial - 1.716.662.0406

Email: industrialsales@enidine.com

Online: www.enidine.com





With its world headquarters located in Orchard Park, New York, USA, **ENIDINE Incorporated** is a world leader in the design and manufacture of standard and custom energy absorption and vibration isolation product solutions within the Industrial, Aerospace, Defense, Marine and Rail markets. Product ranges include shock absorbers, gas springs, rate controls, air springs, wire rope isolators, heavy industry buffers and emergency stops. With facilities strategically located throughout the world and in partnership with our vast global network of distributors, Enidine Incorporated continues to strengthen its presence within marketplace.

Founded in 1966, Enidine Incorporated now has close to 600 employees located throughout the globe in the United States, Germany, France, Japan, China and Korea. With a team of professionals in engineering, computer science, manufacturing, production and marketing our employees provide our customers the very best in service and application solutions.

“Enidine is widely recognized as the preferred source for energy absorption and vibration isolation products.”

From Original Equipment Manufacturers (OEM) to aftermarket applications, Enidine offers a unique combination of product selection, engineering excellence and technical support to meet even the toughest energy absorption application requirements.

Global Manufacturing and Sales Facilities offer our customers:

- ***Highly Trained Distribution Network***
- ***State-of-the Art Engineering Capabilities***
- ***Custom Solution Development***
- ***Customer Service Specialists***
- ***Multiple Open Communication Channels***

If you are unsure whether one of our standard products meets your requirements, feel free to speak with one of our technical representatives **toll-free at 1-800-852-8508**, or contact us via **e-mail at industrialsales@enidine.com**.

Products/Engineering/Technical Support

Enidine continually strives to provide the widest selection of shock absorbers and rate control products in the global marketplace. Through constant evaluation and testing, we bring our customers the most cost effective products with more features, greater performance and improved ease of use.

Global Service & Support

Enidine offers its customers a global network of customer service staff and technical sales personnel that are available to assist you with all of your application needs.

- Operating with lean manufacturing and cellular production, Enidine produces higher quality custom and standard products with greater efficiency and within shorter lead times.
- An authorized Global Distribution Network is trained regularly by ENIDINE staff on new products and services ensuring they are better able to serve you.
- Global operations in USA, France, China, Japan and Korea.
- A comprehensive, website full of application information, technical data, sizing examples and information to assist in selecting the product that's right for you.

Our website also features a searchable worldwide distributor lookup to help facilitate fast, localized service. Contact us today for assistance with all of your application needs.

Our global customer service and technical sales departments are available to assist you find the solution that's right for your application needs. Call us at 1.800.852.8508 or e-mail us at industrialsales@enidine.com and let us get started today.



Enidine Air Springs are highly durable, precisely engineered and cost-effective for use in a wide variety of actuation and vibration isolation applications. With time-tested designs, fabric-reinforced Neoprene or Natural Rubber flex member construction and corrosion-protected end retainers, Enidine Air Springs provide superior quality and performance.

As an actuator, Enidine Air Springs provide linear or angular motion. These Air Springs offer a favorable stroke-to-compressed-height ratio when compared to air cylinders, and can accept a wide variety of actuation media such as air, water, nitrogen or anti-freeze.

As an isolator, Enidine Air Springs are effective in reducing the harmful effects of vibration. They can simultaneously isolate vibration and regulate load height, as well as allow for consistent vibration isolation under varying loads.

Enidine offers a variety of Air Spring types to meet your actuation or isolation needs. The Single, Double and Triple Convolute Bellows, Rolling Lobe and Sleeve Types are available in a wide range of sizes, with the End Retainer Style required for your installation.

Temperature Range Guidelines

Enidine Air Springs are constructed of either Natural Rubber or Neoprene elastomeric compounds. The temperature range guidelines for air spring applications vary depending on construction and nature of service.

Continuous Service

The maximum operating temperature for all Enidine Air Springs should not exceed 135°F (57°C). Continuous service is defined as operating 40 or more hours per week at this temperature. Minimum allowable operating temperature is -20°F (-29°C) for air spring products made with Neoprene, -56°F (-49°C) for products made with Natural Rubber.

Intermittent Service

The maximum allowable temperature should not exceed 150°F (65°C). Intermittent Service is defined as operating less than 40 hours per week at this temperature. Minimum allowable operating temperature is -40°F (-40°C) for products made with Neoprene and -76°F (-60°C) for products made with Natural Rubber. Note that minor cracking may occur with any prolonged operation at these minimum temperatures.

Enisize for Air Springs

Enisize for Air Springs is primarily an automated selection program designed to provide qualified users with recommendations. Due to the nature and scope of this program, all previously existing or imbedded catalog documentation is superceded by the data and results generated by Enisize for Air Springs. It is the user's sole responsibility for the use of this program and its results. The program contains the latest information available at the time of release and is subject to change without notice.

The contents of this publication are the result of many years of research and experience gained in application technology. All information is given in good faith; it does not represent a guarantee with respect to characteristics and does not exempt the user from testing the suitability of products, including checking with respect to industrial property rights of any third parties. No liability whatsoever will be accepted for damage, regardless of its nature and its legal basis, arising from advice given in this publication. Products are subject to technical changes as a result of new developments.

Sizing Software

Enisize for Air Springs (E.A.S.) can help you size the proper Air Spring for your application. Once installed on your PC, just launch the program from the E.A.S. ICON on your desktop. The program will need a few input parameters to provide you with Air Spring recommendations.

You can review all the important technical information required to specify the Air Spring in your application. Your results can be viewed within the program or saved onto your desktop in a convenient PDF format for printing or e-mailing. For more product information or pricing, please contact Enidine's customer service department at 1.800.852.8508.

Supported operating systems

- Windows® 98/98SE
- Windows® ME
- Windows® NT with Service Pack 6a or better
- Windows® 2000 with latest Service Pack
- Windows® XP Home or Pro Versions
- Windows® server 2003 Family Release Versions Only

Required software installation*

- Microsoft® .net framework automatically installed by program installer.
 - Microsoft® data access components (mdac) 2.6 or later Provided on CD and installed by user. The program will prompt for installation if necessary.
 - Microsoft® Internet Explorer® 5.0 or later
 - Adobe® Acrobat Reader® 5.0 or later, may be downloaded at: www.adobe.com
- *Please contact Enidine for installation assistance if required.

Minimum hardware requirements

- Pentium® 133mhz *(Or minimum required by the operating system)*
- 128 megabytes of ram *(Or minimum required by the operating system)*
- 150 megabytes of free hard disk space *(Estimated)*

To obtain a CD-ROM copy of this sizing program contact us at: 1-800-852-8508 or download the program at www.enidine.com



Advantages of Enidine Air Springs

Introduction

Simple construction

Varying loads can be supported by one Air Spring size. Therefore, no re-design is necessary for varying loads.

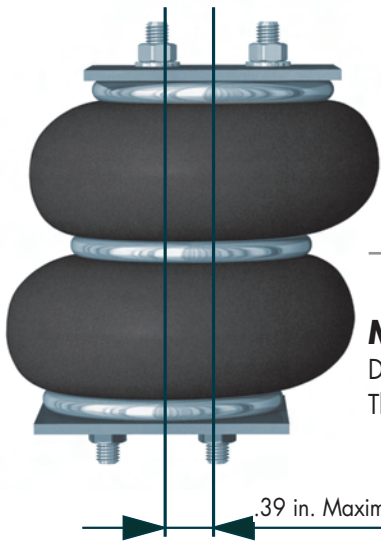
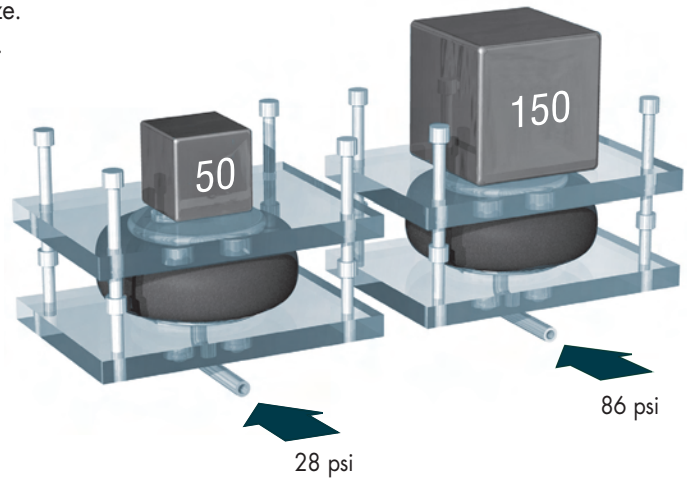

Max. displacement .39 in.

Displacement permissible between upper and lower end plate. Therefore, no costly machining of mounting holes is necessary.

Maximum tilt angle of 25°

A maximum tilt angle of 25° is allowable. No costly reversing devices are necessary. Contact Enidine or your local representative for technical help.

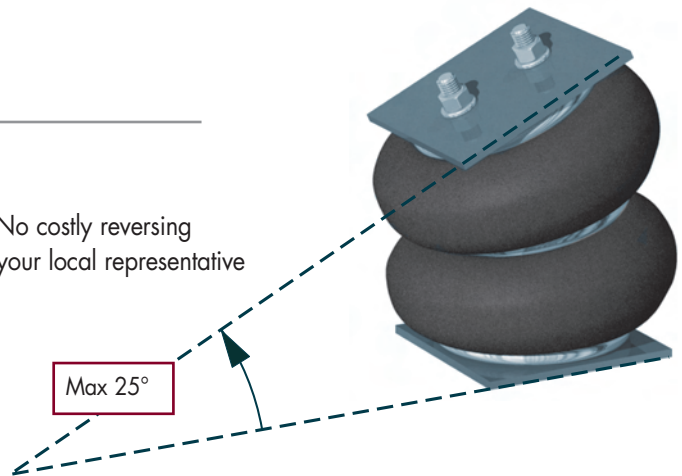

Little space required, no sealing required

Compared to conventional pneumatic cylinders, the minimum height of the Enidine Air Spring is significantly lower at the same stroke.

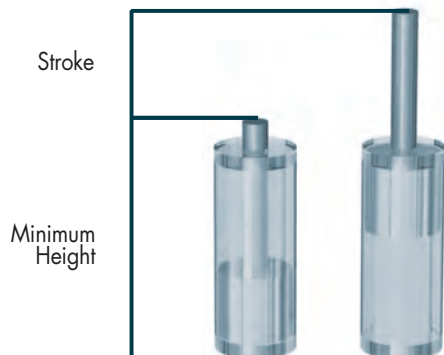

Standard Materials

Flex Members: Fabric-reinforced Neoprene
 Fabric-reinforced natural rubber

End Retainers: Forged steel
 Cast zinc alloy
 Cast aluminum

Operating Temperature Range

Fabric-reinforced Neoprene: -40°F to 150°F
 (-40°C to 65°C)

Fabric-reinforced Natural Rubber: -76°F to 150°F
 (-60°C to 65°C)

NOTE: See temperature range guidelines on page 4, for details.

Environmental Considerations

Good for most industrial applications. Can be affected by certain chemicals. Contact Enidine or your Local Representative for specific information.

Ordering Information

EXAMPLE:

100 YI-1B6 - 535

1. Select Quantity **2. Select Product Description Number from Selection Chart** **3. Select Assembly Number from Selection Chart**

Model Number

Accessories

Assembly (Stud + Nut + Washer)

Part Number	A	B	H in.	V in.	X in.
YI-578-29-056	1/2" UNC	3/8" UNC	.53	2.50	.56

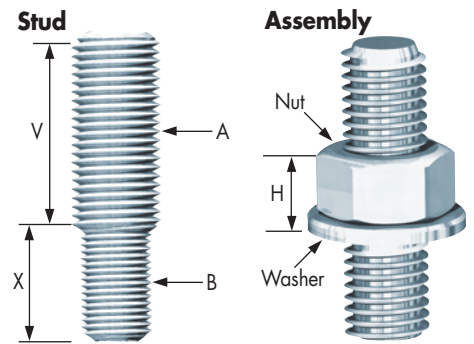

Tank Valves Including Safety Cap

Part Number	A	B in.	V in.	X in.	Y in.	Z in.
YI-579-08-9-033	1/8" NPTF	.44	.31	1.31	.38	.75
YI-578-92-9-122	1/4" NPTF	.56	.31	1.31	.56	.56
YI-579-08-9-033M	1/8" BSP	.51	.31	1.66	.51	.87
YI-578-92-9-122M	1/4" BSP	.91	.31	1.66	.51	.87

Tank Valve Including Safety Cap

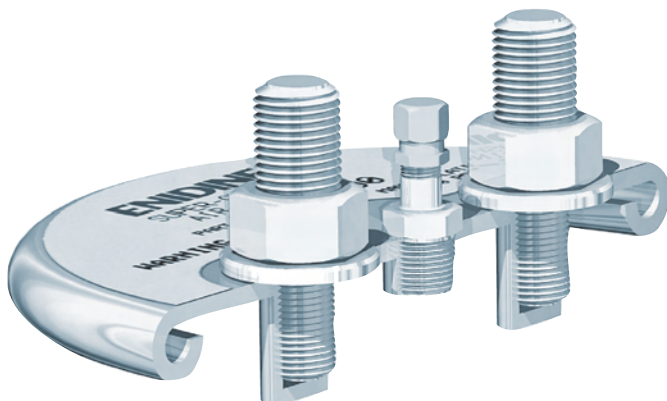
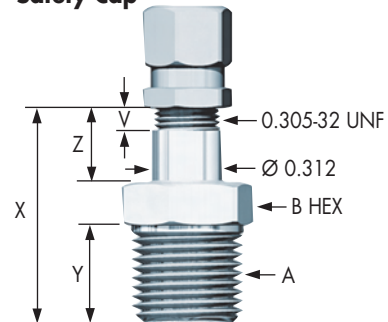

Typical Applications for Actuation

Scissor Lifts

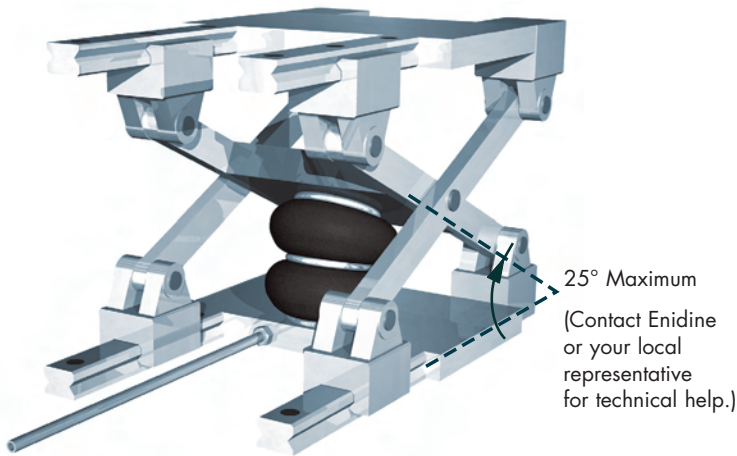

- Scissor lifts
- Injection or ejection of parts in manufacturing equipment
- Vertical lift force for platforms and rotating tables
- Conveyor or transfer systems
- Rotary shaft actuators

Presses

- Bin-tilting devices
- Palletizers, label applicators in packaging equipment
- Amusement park rides
- Clutch and brake systems

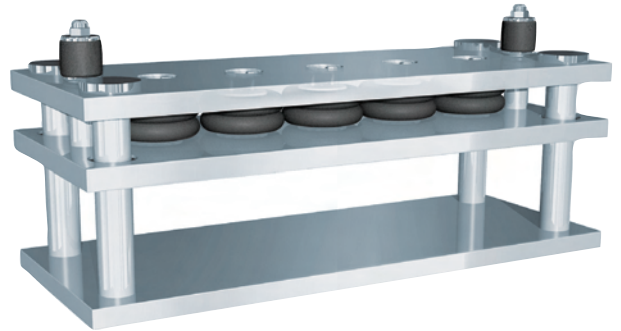

Typical Applications for Vibration Isolation

Compressors

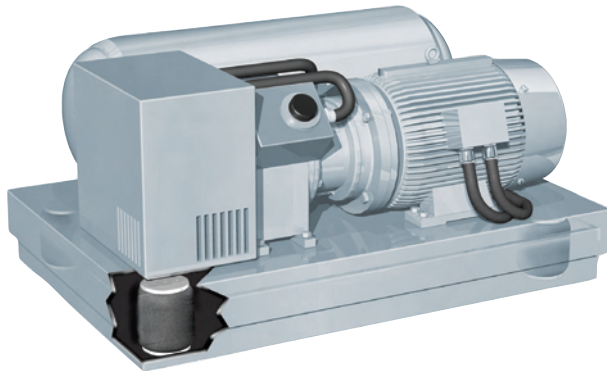

- Vibratory conveyors
- Large drying machines
- Centrifugal separators
- Coordinate measuring tables and machinery
- Commercial laundry machines

Electronic Equipment

- Textile looms
- Conveyor loading points
- Compressors
- Electronic equipment



Installation and Operating Instructions

Provide stroke limitations,
to prevent exceeding the maximum allowable stroke height.

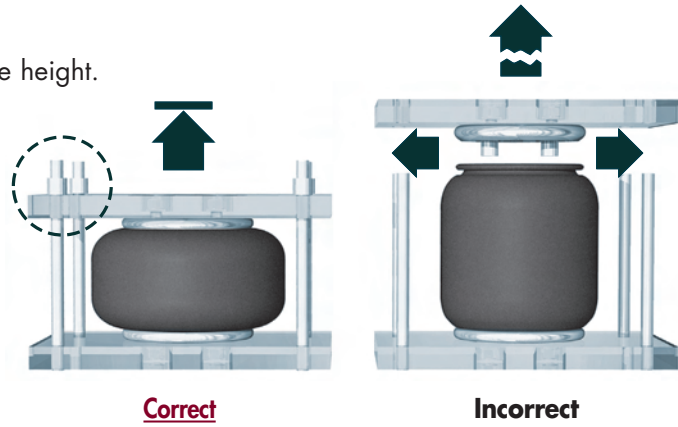

Provide stops for minimal height,
or use Air Springs with, optional Internal Bumper.

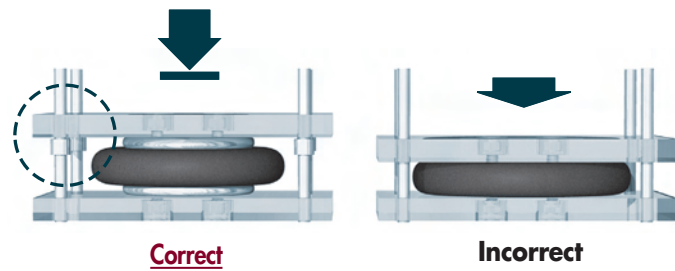

Max. allowable pressure: 100 psi (7 bar).

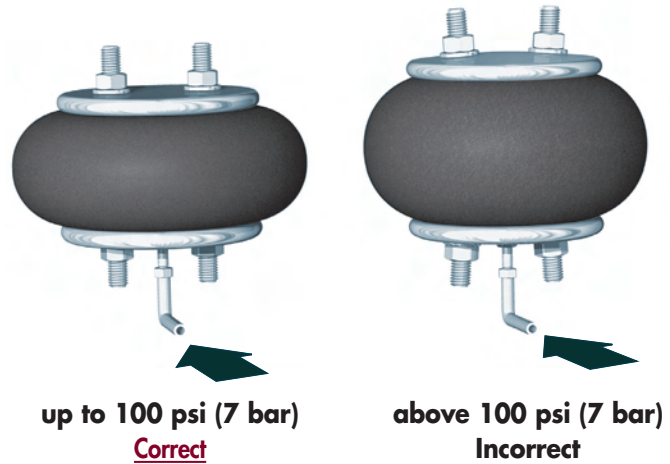

Never use Air Springs in torsion.

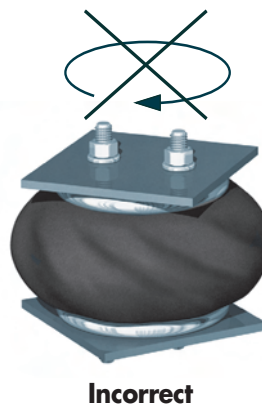

Application Worksheet: Actuation

The following data should be given:	Symbol	Unit	Calculation:
1. Total force required for actuation	F_i	_____ lbs.	Force per Air Spring $F = \frac{F_i}{n}$ lbs.
2. Number of actuators	n	_____	
3. Stroke required	s	_____ in.	Example: $F_i = 4,400$ lbs. $n = 4$ $F = \frac{4,400 \text{ lbs.}}{4}$ $F = 1,100$ lbs.
4. Available air pressure at the point of installation	p	_____ psi	
5. Working temperature range	t	_____ °F	
6. An internal bumper will be required if any of the following conditions occur: <ul style="list-style-type: none"> • External compression stops are not provided • Severe impacting at the compressed height of the Air Spring. 		<input type="checkbox"/> Internal Bumper <input type="checkbox"/> No Bumper	Example: $p = 50$ psi $F_c = \frac{1,100 \times 100}{50}$ $F_c = 2,200$ lbs.
7. Is a constant actuation force required for this application?		<input type="checkbox"/> Yes - only Sleeve and Rolling Lobe Type Air Springs <input type="checkbox"/> No - all type Air Springs <input type="checkbox"/> Yes	

*All Force values in the Selection Chart are based on a maximum operating pressure of 100 psi. Actual force capabilities of the Air Spring depends on the air pressure available. The Corrected Force calculation compensates for available air pressure.

Sizing Instructions

Step 1: Fill out the Application Worksheet.

Step 2: In most applications, a constant actuation force over the stroke is not required and sizing should begin with Single Convolute Bellows Type Air Springs. However, if a constant actuation force over the stroke is required, consider only the Sleeve and Rolling Lobe Type Air Springs.

Step 3: Refer to the Selection Chart under **Actuation Specifications**. In the **Force lbs. @ 100 psi @ A Stroke Of:** Data Table choose the column that is equal to or exceeds the Stroke Required (S) (i.e., if a stroke of 2.5 in. is required, refer to the **3.0 in.** column). Identify the first Air Spring model that will generate a force equal to or greater than the Corrected Force (F_c) required. This is the Endidine Air Spring that will best serve your application. Select a model that includes an internal bumper if one is needed in the application. Availability of internal bumpers can be found under the **Features** table for each Air Spring.

Step 4: Verify the **Envelope Dimensions** of the selected Endidine Air Spring to ensure that the Air Spring will fit the application. Allow a 2 in. clearance on the diameter to prevent abrasion of the flex member. Select the **Model Number** that provides the **Features** and **Mounting Dimensions** required for the application.

Installation Considerations

- External extension stops are required to limit the extension of the Air Spring(s).
- The path of motion must be guided, as Air Springs provide little lateral stability.

Sizing Example

A 3,200 lb. conveyor carrying an 1,200 lb. package needs to be lifted 1.8 in. to transfer the package to another conveyor. There will be four Actuators utilized and the warehouse has air lines with 50 psi. A constant actuation force is not required. Ambient temperature is 68°F. There is a 12 in. square space to house each Air Spring. Compression and extension stops are provided. Any **Air Fitting Port** and **End Retainer Style** would be acceptable.

Step 1: From the completed Application Worksheet, we know:

- Corrected force per actuator is 2,200 lbs.
- Stroke required is 1.8 inches
- An internal bumper is not required
- A constant actuation force is not required
- Working temperature is 68°F

Step 2: A constant force is not needed. Therefore, all Air Spring types are considered, beginning with Single Convolute Bellows.

Step 3: In the **2.0 in.** column under the **Force lbs. @ 100 psi @ A Stroke Of:** Data Table, identify an Air Spring that can generate 2,200 lbs. of force. No internal bumper is required. Model YI-1B8-550 is selected.

Step 4: The maximum diameter of a YI-1B8-550 is 8.7 in. Therefore, we need a 10.7 in. diameter space to house the Air Spring. A 12 in. square space will easily house the Air Spring. Any **Air Fitting Port** and **End Retainer Style** would be acceptable. Model YI-1B8-550 is selected.

Application Worksheet: Vibration Isolation

The following data should be given:	Symbol	Unit	Calculation:
1. Total load	W_i	_____ lbs.	Load per Air Spring: $W = \frac{W_i}{n} =$ _____ lbs.
2. Number of isolators	n	_____	
3. Input excitation frequency	f_i	CPM or RPM/60 = Hz _____ Hz	Corrected Load [W_c]: $W_c = \frac{W \times 100 \text{ psi}^*}{p}$ $W_c =$ _____ lbs.
4. Available air pressure at the point of Installation	p	_____ psi **	
5. Working temperature range	t	_____ °F	Example: $W_i = 8,500 \text{ lbs.}$ $n = 4$ $W = \frac{8,500}{4}$ $W = 2,125 \text{ lbs.}$ Example: $p = 100 \text{ psi}$ $W_c = \frac{2,125 \times 100}{100}$ $W_c = 2,125 \text{ lbs.}$
6. Required isolation	I	<input type="checkbox"/> 80 % <input type="checkbox"/> 90 % <input type="checkbox"/> Internal Bumper <input type="checkbox"/> No Bumper	
7. An internal bumper will be required if any of the following conditions occur: - External compression stops are not provided. - Severe impacting at the compressed height of the Air Spring. - Operation of vibrating equipment on a deflated Air Spring.		<input type="checkbox"/> Yes	

*All Load values in the Selection Charts are based on a maximum operating pressure of 100 psi. Actual load bearing capabilities of the Air Spring depend on the air pressure available. The Corrected Load calculation compensates for available air pressure.
 ** If no air lines are available, a tank valve should be utilized; use 100 psi to select an Air Spring.

Sizing Instructions

Step 1: Fill out the Application Worksheet.

Step 2: Refer to the Selection Chart under **Isolation Specifications**. In the **Isolator Load Range @ 100 psi** column, identify the first Air Spring model that will support the Corrected Load (W_c) required for the application. Check the Data Table for **Percent Isolation at an Input Frequency Of:** and compare the Input Excitation Frequency (f_i) to the input frequencies listed. Referring to the percent isolation for the model identified, estimate the approximate percent of isolation. If the first model identified does not meet the isolation requirements, then select the model that will **both** support the Corrected Load (W_c) and provide the required percent of isolation. Select a model that includes an internal bumper, if one is needed in the application. Availability of internal bumpers can be found under the **Features** Table for each Air Spring.

Step 3: Verify the **Envelope Dimensions** of the selected Air Spring to ensure that the Air Spring will fit the application. Allow a 2 in. clearance on the diameter to prevent abrasion of the flex member. Select the **Model Number** that provides the **Features** and **Mounting Dimensions** required for the application.

Installation Considerations

- To ensure stability, the distance from the floor to the center of gravity of the load should not exceed the shortest distance between Air Springs.
- Air Springs provide little lateral stability. Therefore, be sure to include a method of stabilization.
- Pressurize the Air Spring only when it is loaded.

Sizing Example

Vibrations generated by a pump weighing 8,500 lbs. and rotating at 600 RPM are being transmitted onto sensitive monitors, causing them to malfunction. To control these damaging vibrations, four Isolators, located symmetrically about the center of gravity, will be used. The ambient temperature range is 60°F to 140°F. Air lines are not available at the site. Therefore, a tank valve will be used. There is the possibility of depressurization of the Air Spring. An isolation of greater than 90% is required. There is a 12 in. diameter space to house the Air Spring. Any **Air Fitting Port** and **End Retainer Style** would be acceptable.

- Step 1:** From the completed Application Worksheet, we know:
- Load per isolator is 2,125 lbs.
 - Because a tank valve is being utilized, size using 100 psi
 - Corrected load per isolator is 2,125 lbs.
 - Working temperature range is 60°F to 140°F
 - Because of the possibility of depressurization, an internal bumper is required
 - Input excitation frequency is 600 CPM

Step 2: The first Enidine Imperial Air Spring model that has an internal bumper and is capable of supporting the Corrected Load Per Isolator is the YI-1B8-554. This Air Spring provides 90% isolation at 435 CPM and 96% at 870 CPM. Therefore, at 600 CPM, the percent isolation is estimated to be 90%.

Step 3: The maximum diameter of a YI-1B8-554 is 8.7 in. Therefore, we need a 10.7 in. diameter space to house the Air Spring. A 12 in. diameter is available. Any **Air Fitting Port** and **End Retainer Style** would be acceptable. Imperial Model YI-1B8-554 is selected. (Note: this model has no internal bumper, therefore external endstops must also be used.)

Single Convolute Type Air Springs

Bold numbers indicate featured stock – contact Enidine customer service for details.

Imperial Single Convolute Bellows Type

MODEL NUMBER		ACTUATION SPECIFICATIONS						ISOLATION SPECIFICATIONS					
Product Description Number	Assembly Number	Maximum Stroke (in.)	FORCE (lbs.) @ 100 psi AT A STROKE OF:*				Isolator Load Range @ 100 psi** (lbs.)	Approximate System Natural Frequency Hz	Design Height Range (in.)	% ISOLATION AT INPUT FREQ OF:***			
			1.0 (in.)	2.0 (in.)	3.0 (in.)	Maximum Stroke				7.25 Hz	14.5 Hz	30 Hz	
YI-1B5	500	502	2.00	1,250	560	—	560	1,100 – 1,350	3.25	2.5 – 3.0	72	94	98
	510	512	3.00	1,500	1,200	520	520	1,050 – 1,500	2.75	2.5 – 4.0	82	96	99
	520	521	3.00	1,500	1,150	440	440	1,000 – 1,500	2.67	3.5 – 5.0	83	96	99
YI-1B6	530		2.80	1,900	1,500	—	850	1,500 – 1,900	2.75	3.0 – 4.0	78	95	98
	531		2.80	1,900	1,500	—	850	1,500 – 1,900	2.75	3.0 – 4.0	78	95	98
	532		2.50	1,800	1,300	—	850	1,500 – 1,900	2.75	3.0 – 4.0	78	95	98
	535		3.40	2,000	1,600	1,025	750	1,500 – 2,100	2.25	4.0 – 6.0	90	97	99
	536		3.40	2,000	1,600	1,025	750	1,500 – 2,100	2.25	4.0 – 6.0	90	97	99
	538		3.40	2,000	1,600	1,025	750	1,500 – 2,100	2.25	4.0 – 6.0	90	97	99
YI-1B7	540		3.20	2,400	1,900	1,100	850	1,600 – 2,200	2.67	3.5 – 4.5	83	96	99
	541		3.20	2,400	1,900	1,100	850	1,600 – 2,200	2.67	3.5 – 4.5	83	96	99
	542		2.90	2,300	1,750	—	850	1,600 – 2,200	2.67	3.5 – 4.5	83	96	99
YI-1B8	550		3.30	3,300	2,650	1,600	1,100	2,000 – 2,900	2.83	3.75 – 4.75	83	96	99
	552		3.30	3,300	2,650	1,600	1,100	2,000 – 2,900	2.83	3.75 – 4.75	83	96	99
	553		3.30	3,300	2,650	1,600	1,100	2,000 – 2,900	2.83	3.75 – 4.75	83	96	99
	554		3.00	3,200	2,500	1,100	1,100	2,000 – 2,900	2.83	3.75 – 4.75	83	96	99
	560	562	3.20	3,100	2,700	1,900	1,600	1,900 – 3,300	2.33	4.0 – 6.5	85	96	99
	563		3.20	3,100	2,700	1,900	1,600	1,900 – 3,300	2.33	4.0 – 6.5	85	96	99
	564		3.20	3,100	2,700	1,900	1,600	1,900 – 3,300	2.33	4.0 – 6.5	85	96	99
YI-1B9	202	204	2.90	5,050	4,150	—	2,850	3,200 – 3,900	2.50	4.5 – 5.0	84	96	99
	201	205	2.00	4,150	2,850	—	2,850	3,200 – 3,900	2.50	4.5 – 5.0	84	96	99
	207		2.90	5,050	4,150	—	2,850	3,200 – 3,900	2.50	4.5 – 5.0	84	96	99
	208		2.00	4,150	2,850	—	2,850	3,200 – 3,900	2.50	4.5 – 5.0	84	96	99
YI-1B12	313	304	3.30	8,700	8,000	7,000	6,574	7,300 – 8,800	2.33	3.0 – 5.0	89	97	99
	301	305	3.00	8,500	7,650	6,574	6,574	7,300 – 8,800	2.33	3.0 – 5.0	89	97	99
YI-1B14	350	352	3.30	12,650	11,500	9,900	9,300	10,000 – 11,900	2.33	4.0 – 5.25	86	96	99
	351	353	1.40	10,000	—	—	9,300	10,000 – 11,750	2.33	4.25 – 5.25	86	96	99
	364	362	6.00	13,500	12,800	11,600	4,800	11,600 – 13,500	2.25	3.25 – 5.25	87	97	99
YI-1B15	375	377	3.5	14,900	13,900	12,200	11,300	12,000 – 13,700	2.17	4.4 – 5.4	91	97	99
	376	378	1.6	12,400	—	—	11,300	12,000 – 13,700	2.17	4.4 – 5.4	91	97	99

Important Note: All catalog performance data is based on 100 psi maximum operating pressure. For product selection at pressures less than 100 psi, please refer to the manual selection procedure within this catalog, use our automated sizing software E.A.S., or contact Enidine customer service at 1-800-852-8508.

End Retainer Styles

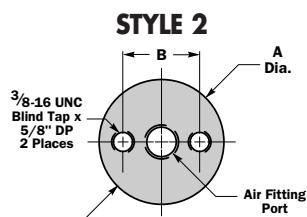

Upper End Retainer shown
Lower End Retainer identical minus Air Fitting Port

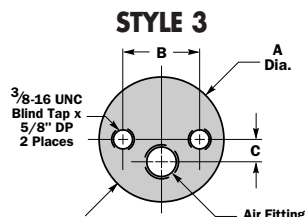

Upper End Retainer shown
Lower End Retainer identical minus Air Fitting Port

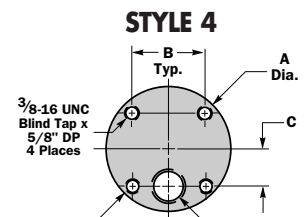

Upper End Retainer shown
Lower End Retainer identical minus Air Fitting Port

* Listed strokes start from the minimum allowable height of the Air Spring.

** To obtain the lower load range limit (i.e., minimum load @ 20 psi), divide the smaller value by 5.

*** In the "Isolation Specification" section, this data reflects the approximate percentage of isolation obtainable, if the design height is at the center of the design height range, and the load per air spring is within the isolator load range. Note: For values other than 100 psi, consult factory.

Single Convolute Type Air Springs

Bold numbers indicate featured stock – contact Enidine customer service for details.

Imperial Single Convolute Bellows Type

ENVELOPE DIMENSIONS					MOUNTING DIMENSIONS			FEATURES					
Maximum Diameter @ 100 psi (in.)	Compressed Height (in.)	Minimum Height as Actuator (in.)	Maximum Height as Insulator (in.)	Maximum Height as Actuator (in.)	A End Plate Ref. Diam. (in.)	B Blind Top Spacing (in.)	C Fill Port Offset (in.)	End Retainer Style	Air Fitting Port (NPTF)	Internal Bumper	Assembly Number	Flex Member Material	
5.70	1.80	1.80	3.80	3.80	3.40	1.75	—	2	1/4	3/4	NO	500 502	NP
6.00	1.80	1.80	4.80	4.80	3.40	1.75	—	2	1/4	3/4	NO	510 512	
6.50	1.80	2.80	5.80	5.80	3.40	1.75	—	2	1/4	3/4	NO	520 521	
6.50	2.00	2.00	4.80	4.80	4.15	1.75	—	2	1/4	NO	530	NP	
6.50	2.00	2.00	4.80	4.80	4.15	2.75	1.38	3	1/4	NO	531		
6.50	2.00	2.30	4.80	4.80	4.15	2.75	1.38	3	1/4	YES	532		
7.00	2.00	2.00	7.10	7.10	4.15	1.75	—	2	1/4	NO	535		
7.00	2.00	2.00	7.10	7.10	4.15	2.75	1.38	3	1/4	NO	536		
7.00	2.00	2.30	7.10	7.10	4.15	2.75	1.38	3	1/4	YES	538		
7.70	2.00	2.00	5.20	5.20	4.15	1.75	—	2	1/4	NO	540	NP	
7.70	2.00	2.00	5.20	5.20	4.15	2.75	1.38	3	1/4	NO	541		
7.70	2.00	2.30	5.20	5.20	4.15	2.75	1.38	3	1/4	YES	542		
8.70	2.00	2.00	5.30	5.30	5.00	2.75	—	2	1/4	NO	550	NP	
8.70	2.00	2.00	5.30	5.30	5.00	2.75	—	2	3/4	NO	552		
8.70	2.00	2.00	5.30	5.30	5.00	2.75	1.38	3	1/4	NO	553		
8.70	2.00	3.50	5.30	5.30	5.00	2.75	1.38	3	1/4	YES	554		
9.40	2.00	3.50	6.70	6.70	5.00	2.75	—	2	1/4	3/4	NO		560 562
9.40	2.00	3.50	6.70	6.70	5.00	2.75	1.38	3	1/4	NO	563		
9.40	2.00	3.50	6.70	6.70	5.00	2.75	1.38	3	1/4	YES	564		
11.00	2.30	2.30	5.90	5.20	6.40	3.50	1.75	3	1/4	1/2	NO	202 204	NR
11.00	2.30	3.20	5.90	5.20	6.40	3.50	1.75	3	1/4	1/2	YES	201 205	
11.00	2.30	2.30	5.90	5.20	6.40	3.50	1.50	3	3/4	NO	207		
11.00	2.30	3.20	5.90	5.20	6.40	3.50	1.50	3	3/4	YES	208		
13.20	2.30	2.30	7.20	5.60	9.00	6.20	2.87	3	1/4	3/4	NO	313 304	NR
13.20	2.30	2.60	7.20	5.60	9.00	6.20	2.87	3	1/4	3/4	YES	301 305	
15.20	2.30	2.30	7.20	5.60	11.30	6.25	3.12	4	1/4	3/4	NO	350 352	NR
15.20	2.30	4.20	7.20	5.60	11.30	6.25	3.12	4	1/4	3/4	YES	351 353	
15.90	2.30	2.30	8.30	8.30	11.30	6.25	3.12	4	1/4	3/4	NO	364 362	
17.50	2.30	2.30	7.90	5.80	11.30	6.25	3.12	4	1/4	3/4	NO	375 377	NR
17.50	2.30	4.20	7.90	5.80	11.30	6.25	3.12	4	1/4	3/4	YES	376 378	

NOTE: NP= Neoprene
NR= Natural Rubber



(Single) Bellows Type

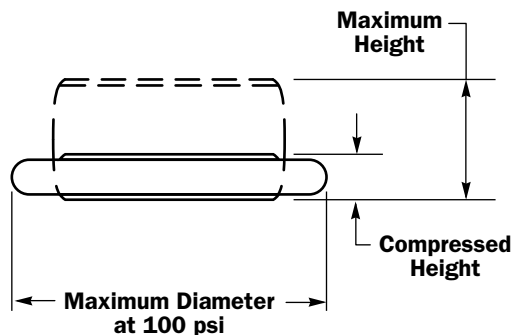

Double Convolute Type Air Springs

Bold numbers indicate featured stock – contact Enidine customer service for details.

Imperial Double Convolute Bellows Type												
MODEL NUMBER		ACTUATION SPECIFICATIONS					ISOLATION SPECIFICATIONS					
Product Description Number	Assembly Number	Maximum Stroke (in.)	FORCE (lbs.) @ 100 psi AT A STROKE OF:*				Isolator Load Range @ 100 psi** (lbs.)	Approximate System Natural Frequency Hz	Design Height Range (in.)	% ISOLATION AT INPUT FREQ OF:***		
			2.0 (in.)	4.0 (in.)	6.0 (in.)	Maximum Stroke				7.25 Hz	14.5 Hz	30 Hz
YI-2B6	530	4.90	1,900	1,100	—	580	1,300 – 2,000	2.09	4.5 – 6.5	85	96	99
	531	4.90	1,900	1,100	—	580	1,300 – 2,000	2.09	4.5 – 6.5	85	96	99
	532	4.30	1,700	800	—	580	1,300 – 2,000	2.09	4.5 – 6.5	85	96	99
	535	6.30	2,350	1,600	700	560	1,500 – 2,200	2.09	5.0 – 7.0	92	97	99
	536	5.70	2,100	1,450	—	560	1,500 – 2,200	2.09	5.0 – 7.0	92	97	99
YI-2B7	540 546	6.50	2,900	2,300	1,250	800	1,600 – 2,500	2.08	6.0 – 8.0	91	97	99
	541	6.50	2,900	2,300	1,250	800	1,600 – 2,500	2.08	6.0 – 8.0	91	97	99
	542	5.70	2,750	2,000	—	800	1,600 – 2,500	2.08	6.0 – 8.0	91	97	99
YI-2B8	550 552	7.20	3,600	2,700	1,800	1,000	2,300 – 2,700	1.92	7.0 – 8.0	93	97	99
	553	7.20	3,600	2,700	1,800	1,000	2,300 – 2,700	1.92	7.0 – 8.0	93	97	99
	554	6.60	3,350	2,500	1,400	1,000	2,300 – 2,700	1.92	7.0 – 8.0	93	97	99
YI-2B9	200 204	6.30	4,650	3,850	2,550	2,300	2,300 – 3,700	1.92	7.5 – 9.5	92	97	99
	201 205	5.70	4,400	3,550	2,100	2,300	2,300 – 3,700	1.92	7.5 – 9.5	92	97	99
	216	6.30	4,650	3,850	2,550	2,300	2,300 – 3,700	1.92	7.5 – 9.5	92	97	99
	208	5.70	4,400	3,550	2,100	2,300	2,300 – 3,700	1.92	7.5 – 9.5	92	97	99
	250*	7.70	4,800	4,000	3,250	2,500	3,000 – 3,800	1.67	8.0 – 10.0	93	98	99
	251*	6.90	4,700	3,900	3,100	2,500	3,000 – 3,800	1.67	8.0 – 10.0	93	98	99
	255	6.90	4,700	3,900	3,100	2,500	3,000 – 3,800	1.67	8.0 – 10.0	93	98	99
	256 263	7.20	4,800	4,000	3,250	2,500	3,000 – 3,800	1.67	8.0 – 10.0	93	98	99
	275	7.20	4,800	4,000	3,250	2,500	3,000 – 3,800	1.67	8.0 – 10.0	93	98	99
YI-2B12	425 429	6.10	8,400	7,200	5,200	5,200	5,200 – 7,200	1.83	7.5 – 9.5	92	98	99
	309 318	5.30	8,050	6,600	—	5,200	5,200 – 7,200	1.83	7.5 – 9.5	92	98	99
	437	6.10	8,400	7,200	5,200	5,200	5,200 – 7,200	1.83	7.5 – 9.5	92	98	99
	416 419	8.40	8,200	7,200	6,900	4,500	7,100 – 8,100	1.58	7.5 – 9.5	92	98	99
YI-2B14	354 352	6.00	12,900	11,100	8,400	7,900	8,400 – 11,100	1.83	7.5 – 9.5	93	98	99
	355 353	4.80	11,600	9,400	—	7,900	8,400 – 11,100	1.83	7.5 – 9.5	93	98	99
	362 363	8.00	13,500	12,580	11,000	9,100	11,800 – 13,100	1.58	7.5 – 9.5	93	98	99
	452	8.30	13,500	12,580	11,000	9,100	11,800 – 13,100	1.58	7.5 – 9.5	93	98	99
YI-2B15	375 377	6.60	13,700	12,300	10,300	9,000	10,300 – 12,300	1.67	7.5 – 9.5	93	98	99
	376 378	5.40	12,850	10,950	—	9,000	10,300 – 12,300	1.67	7.5 – 9.5	93	98	99

Important Note: All catalog performance data is based on 100 psi maximum operating pressure. For product selection at pressures less than 100 psi, please refer to the manual selection procedure within this catalog, use our automated sizing software E.A.S., or contact Enidine customer service at 1-800-852-8508.

End Retainer Styles

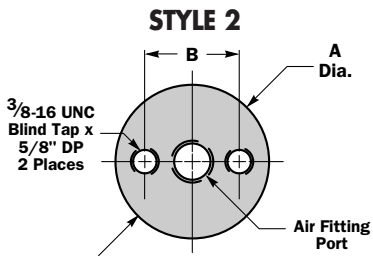

Upper End Retainer shown
Lower End Retainer identical minus Air Fitting Port

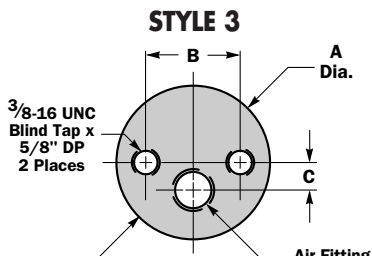

Upper End Retainer shown
Lower End Retainer identical minus Air Fitting Port

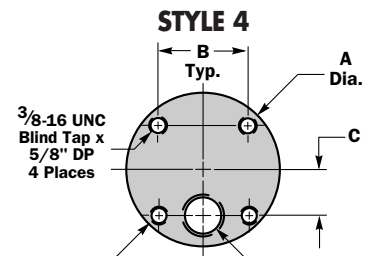

Upper End Retainer shown
Lower End Retainer identical minus Air Fitting Port

* Listed strokes start from the minimum allowable height of the Air Spring.

** To obtain the lower load range limit (i.e., minimum load @ 20 psi), divide the smaller value by 5.

*** In the "Isolation Specification" section, this data reflects the approximate percentage of isolation obtainable, if the design height is at the center of the design height range, and the load per air spring is within the isolator load range. Note: For values other than 100 psi, consult factory.

Double Convolute Type Air Springs

Bold numbers indicate featured stock – contact Enidine customer service for details.

Imperial Double Convolute Bellows Type

Maximum Diameter @ 100 psi (in.)	ENVELOPE DIMENSIONS				MOUNTING DIMENSIONS			FEATURES			Assembly Number	Flex Member Material	
	Compressed Height (in.)	Minimum Height as Actuator (in.)	Maximum Height as Insulator (in.)	Maximum Height as Actuator (in.)	A End Plate Ret. Diam. (in.)	B Blind Tap Spacing (in.)	C Fill Port Offset (in.)	End Retainer Style	Air Fitting Port (NPTF)	Internal Bumper			
6.50	2.80	2.80	7.70	7.70	4.84	1.75	—	2	1/4	NO	530	NP	
6.50	2.80	2.80	7.70	7.70	4.84	2.75	1.38	3	1/4	NO	531		
6.50	2.80	3.40	7.70	7.70	4.84	2.75	1.38	3	1/4	YES	532		
7.00	2.80	2.80	9.10	9.10	4.84	2.75	1.38	3	1/4	NO	535		
7.00	2.80	3.40	9.10	9.10	4.84	2.75	1.38	3	1/4	YES	536		
8.00	2.50	2.50	9.00	9.00	5.00	2.75	—	2	1/4	3/4	540	546	NP
8.00	2.50	2.50	9.00	9.00	5.00	2.75	1.38	3	1/4	NO	541		
8.00	2.50	3.30	9.00	9.00	5.00	2.75	1.38	3	1/4	YES	542		
8.80	2.90	2.90	10.10	10.10	5.87	2.75	—	2	1/4	3/4	550	552	NP
8.80	2.90	2.90	10.10	10.10	5.87	2.75	1.38	3	1/4	NO	553		
8.80	2.90	3.50	10.10	10.10	5.87	2.75	1.38	3	1/4	YES	554		
10.30	3.20	3.20	10.80	9.50	6.40	3.50	1.75	3	1/4	1/2	200	204	NR
10.30	3.20	3.80	10.80	9.50	6.40	3.50	1.75	3	1/4	1/2	201	205	
10.30	3.20	3.20	10.80	9.50	6.40	3.50	1.50	3	3/4	NO	216		
10.30	3.20	3.80	10.80	9.50	6.40	3.50	1.50	3	3/4	YES	208		
10.30	3.50	3.50	12.20	10.70	6.40	3.50	1.75	3†	1/4	NO	250*		
10.30	3.50	3.80	12.20	10.70	6.40	3.50	1.75	3†	1/4	YES	251*		
10.30	3.50	3.80	12.20	10.70	6.40	3.50	1.75	3	1/4	YES	255		
10.30	3.50	3.50	12.20	10.70	6.40	3.50	1.75	3	1/4	1/2	256	263	
10.30	3.50	3.50	12.20	10.70	6.40	3.50	1.50	3	3/4	NO	275		
13.00	3.40	3.40	11.10	9.50	9.00	6.20	2.87	3	1/4	3/4	425	429	NR
13.00	3.40	4.20	11.10	9.50	9.00	6.20	2.87	3	1/4	3/4	309	318	
13.00	3.40	3.40	11.10	9.50	9.00	6.20	—	2	1/4	NO	437		
13.70	4.30	4.30	14.40	12.70	9.00	6.20	2.87	3	1/4	3/4	416	419	
15.10	3.50	3.50	11.30	9.70	11.30	6.25	3.12	4	1/4	3/4	354	352	NR
15.10	3.50	4.90	11.30	9.70	11.30	6.25	3.12	4	1/4	3/4	355	353	
16.00	3.50	3.50	15.20	12.50	11.30	6.25	3.12	4	1/4	3/4	362	363	
16.00	4.50	4.20	15.20	12.50	11.30	6.25	3.12	4	1/4	YES	452		
16.70	3.70	3.70	12.80	10.30	11.30	6.25	3.12	4	1/4	3/4	375	377	NR
16.70	3.70	4.90	12.80	10.30	11.30	6.25	3.12	4	1/4	3/4	376	378	

NOTE: NP= Neoprene
NR= Natural Rubber



(Double) Bellows Type

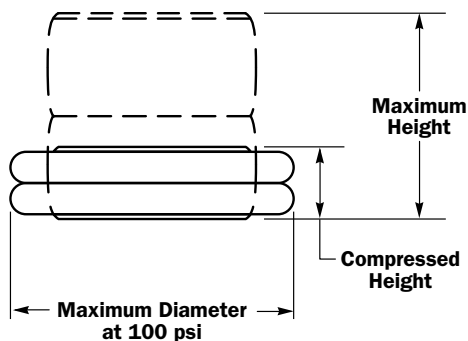

*For Models YI-2B9-250 and YI-2B9-251, the Upper End Retainer is supplied with 1/2-13 UNC X .63 inch long Mounting Studs.

Triple Convolute Type Air Springs

Bold numbers indicate featured stock – contact Enidine customer service for details.

Imperial Triple Convolute Bellows Type

MODEL NUMBER		ACTUATION SPECIFICATIONS						ISOLATION SPECIFICATIONS					
Product Description Number	Assembly Number	Maximum Stroke (in.)	FORCE (lbs.) @ 100 psi AT A STROKE OF:*				Isolator Load Range @ 100 psi** (lbs.)	Approximate System Natural Frequency Hz	Design Height Range (in.)	% ISOLATION AT INPUT FREQ OF:***			
			3.0 (in.)	6.0 (in.)	9.0 (in.)	Maximum Stroke				7.25 Hz	14.5 Hz	30 Hz	
YI-3B12	304 305	10.60	8,500	7,400	5,800	4,600	5,200 – 7,100	1.50	11.0 – 15.0	94	98	99	
	308	10.60	8,500	7,400	5,800	4,600	5,200 – 7,100	1.50	11.0 – 15.0	94	98	99	
	325 326	11.10	10,500	8,750	7,250	5,800	6,300 – 8,400	1.50	11.0 – 15.0	94	98	99	
YI-3B14	450 374	15.80	12,400	10,900	9,650	4,500	10,200 – 11,000	1.25	10.5 – 12.5	95	99	99	
	453 411	15.60	12,250	10,800	9,500	4,500	10,200 – 11,000	1.25	10.5 – 12.5	95	98	99	
	403 361	10.20	13,500	11,900	9,750	8,300	10,700 – 12,100	1.50	10.5 – 12.5	95	98	99	
	351 353	7.90	12,500	10,000	—	8,300	10,700 – 12,100	1.50	10.5 – 12.5	95	98	99	
YI-3B15	375 377	9.90	14,500	12,650	10,100	7,200	11,200 – 12,800	1.42	10.5 – 12.5	91	97	99	
	376 378	7.30	13,000	10,500	—	7,200	11,200 – 12,800	1.42	10.5 – 12.5	91	97	99	

Important Note: All catalog performance data is based on 100 psi maximum operating pressure. For product selection at pressures less than 100 psi, please refer to the manual selection procedure within this catalog, use our automated sizing software E.A.S., or contact Enidine customer service at 1-800-852-8508.

End Retainer Styles

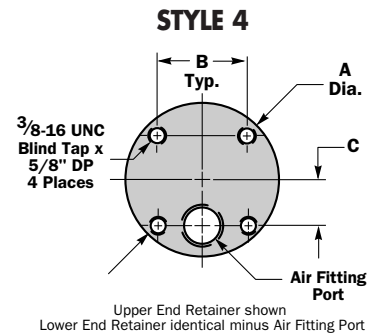
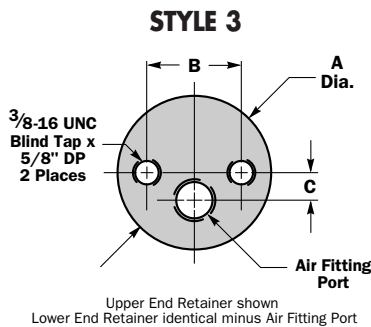
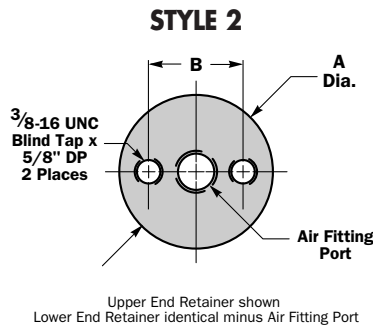

* Listed strokes start from the minimum allowable height of the Air Spring.

** To obtain the lower load range limit (i.e., minimum load @ 20 psi), divide the smaller value by 5.

*** In the "Isolation Specification" section, this data reflects the approximate percentage of isolation obtainable, if the design height is at the center of the design height range, and the load per air spring is within the isolator load range. Note: For values other than 100 psi, consult factory.

Triple Convolute Type Air Springs

Bold numbers indicate featured stock – contact Enidine customer service for details.

Imperial Triple Convolute Bellows Type

ENVELOPE DIMENSIONS					MOUNTING DIMENSIONS			FEATURES					
Maximum Diameter @ 100 psi (in.)	Compressed Height (in.)	Minimum Height as Actuator (in.)	Maximum Height as Insulator (in.)	Maximum Height as Actuator (in.)	A End Plate Ret. Diam. (in.)	B Blind Tap Spacing (in.)	C Fill Port Offset (in.)	End Retainer Style	Air Fitting Port (NPTF)	Internal Bumper	Assembly Number	Flex Member Material	
13.00	4.80	4.80	18.00	15.40	9.00	6.20	2.87	3	1/4	3/4	NO	304 305	NR
13.00	4.80	4.80	18.00	15.40	9.00	6.20	—	2	1/4	NO	308		
13.80	4.60	4.80	19.00	15.70	10.30	6.20	2.87	3	1 1/4	3/4	NO	325 326	
15.50	4.70	4.70	20.50	20.50	11.30	6.25	3.13	4	1/4	3/4	NO	450 374	NR
15.50	4.70	4.90	20.50	20.50	11.30	6.25	3.13	4	1/4	3/4	YES	453 411	
15.50	5.00	5.00	18.00	15.20	11.30	6.25	3.12	4	1/4	3/4	NO	403 361	
15.50	5.00	7.30	18.00	15.20	11.30	6.25	3.12	4	1/4	3/4	YES	351 353	
16.50	4.70	4.70	17.00	14.60	11.30	6.25	3.12	4	1/4	3/4	NO	375 377	NR
16.50	4.70	7.30	17.00	14.60	11.30	6.25	3.12	4	1/4	3/4	YES	376 378	

NOTE: NP= Neoprene
NR= Natural Rubber



(Triple) Bellows Type

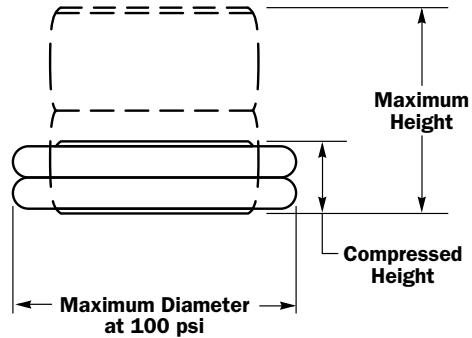

Sleeve and Rolling Lobe Type Air Springs

Bold numbers indicate featured stock – contact Enidine customer service for details.

Imperial Sleeve Type

MODEL NUMBER		ACTUATION SPECIFICATIONS					ISOLATION SPECIFICATIONS					
Product Description Number	Assembly Number	Maximum Stroke (in.)	FORCE (lbs.) @ 100 psi AT A STROKE OF:*				Isolator Load Range @ 100 psi** (lbs.)	Approximate System Natural Frequency Hz	Design Height Range (in.)	% ISOLATION AT INPUT FREQ OF:***		
			1.0 (in.)	3.0 (in.)	5.0 (in.)	Maximum Stroke				7.25 Hz	14.5 Hz	30 Hz
YI-1S3	011	4.40	400	400	—	110	350 – 400	2.00	5.0 – 6.0	92	97	99
	013	2.10	560	—	—	120	440 – 580	3.25	2.0 – 3.0	71	93	98
YI-1S4	007	4.90	850	830	—	310	840 – 850	2.17	3.8 – 4.4	90	97	99
	008	6.50	700	900	850	540	800 – 900	1.33	6.5 – 7.5	95	98	99
YI-1S5	005	5.50	1,000	1,100	900	800	1,000 – 1,100	1.58	6.2 – 7.2	95	98	99
	006	6.50	1,000	1,150	1,100	750	1,100 – 1,150	1.50	7.0 – 9.0	96	99	99
	010	4.00	1,100	950	—	560	1,000 – 1,100	2.00	3.8 – 4.3	90	97	99
YI-1S6	023	6.80	1,700	1,600	1,590	1,200	1,600	1.58	7.0 – 8.6	94	98	99

Imperial Rolling Lobe Type

MODEL NUMBER		ACTUATION SPECIFICATIONS					ISOLATION SPECIFICATIONS					
Product Description Number	Assembly Number	Maximum Stroke (in.)	FORCE (lbs.) @ 100 psi AT A STROKE OF:*				Isolator Load Range @ 100 psi** (lbs.)	Approximate System Natural Frequency Hz	Design Height Range (in.)	% ISOLATION AT INPUT FREQ OF:***		
			4.0 (in.)	8.0 (in.)	12.0 (in.)	Maximum Stroke				7.25 Hz	14.5 Hz	30 Hz
YI-1R8	005	13.00	3,280	2,950	—	—	3,000 – 3,100	1.33	10.5 – 13.0	95	98	99
	009	11.80	2,800	—	—	—	2,700 – 2,900	1.17	10.5 – 13.0	96	98	99
YI-1R9	003	12.30	3,350	3,040	1,300	1,250	3,200 – 3,700	1.42	8.0 – 12.0	93	98	99
	009	8.60	4,150	1,600	—	900	3,900 – 4,400	1.67	6.0 – 7.5	91	97	99
YI-1R10	089	14.10	5,100	5,250	3,550	2,100	5,000 – 5,200	1.25	9.5 – 13.5	96	99	99
YI-1R11	028	9.30	6,450	3,800	—	2,300	5,500 – 6,700	1.58	6.0 – 10.0	95	98	99
	039	11.00	6,700	5,750	—	2,300	6,500 – 7,000	1.67	8.0 – 12.0	94	98	99
YI-1R12	092	13.40	7,440	7,200	4,350	2,700	6,800 – 7,600	1.42	10.5 – 16.5	96	99	99
	095	9.10	7,100	3,800	—	2,400	6,800 – 7,300	1.58	7.0 – 9.0	94	98	99
	103	17.50	7,450	7,050	6,600	2,600	6,900 – 7,300	1.25	15.0 – 20.0	96	99	99
	132	10.80	7,350	5,900	—	2,700	7,400 – 7,600	1.67	8.0 – 10.0	93	98	99
	256	19.60	7,575	7,225	7,000	3,100	7,000 – 7,300	1.17	16.0 – 20.0	96	99	99
	274	14.70	7,400	7,200	5,100	3,000	7,300 – 7,500	1.17	11.3 – 14.3	96	99	99
YI-1R14	019	16.90	8,500	8,500	—	—	8,400 – 8,500	1.17	14.0 – 18.0	96	99	99
	018	14.80	8,400	8,400	6,100	2,500	8,400 – 8,500	1.25	11.0 – 16.5	96	99	99
	037	12.30	10,500	8,500	3,000	2,900	10,400 – 11,000	1.75	7.5 – 11.0	92	98	99

Important Note: All catalog performance data is based on 100 psi maximum operating pressure. For product selection at pressures less than 100 psi, please refer to the manual selection procedure within this catalog, use our automated sizing software E.A.S., or contact Enidine customer service at 1-800-852-8508.

End Retainer Styles

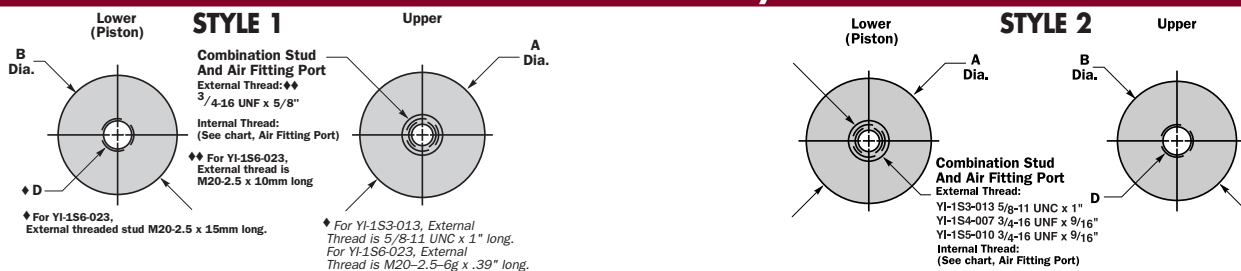

* Listed strokes start from the minimum allowable height of the Air Spring.

** To obtain the lower load range limit (i.e., minimum load @ 20 psi), divide the smaller value by 5.

*** In the "Isolation Specification" section, this data reflects the approximate percentage of isolation obtainable, if the design height is at the center of the design height range, and the load per air spring is within the isolator load range. Note: For values other than 100 psi, consult factory.

Sleeve and Rolling Lobe Type Air Springs

Bold numbers indicate featured stock – contact Enidine customer service for details.

Imperial Sleeve Type

ENVELOPE DIMENSIONS			MOUNTING DIMENSIONS			FEATURES			Assembly Number	Flex Member Material
Maximum Diameter @ 100 psi (in.)	Compressed Height (in.)	Maximum Height (in.)	A Upper End Plate Diam. (in.)	B Lower End Plate Diam. (in.)	D Blind Tap for Mounting (in.)	End Retainer Style	Air Fitting Port (NPTF)	Internal Bumper		
3.25	3.60	8.00	2.75	2.75	1/2-13 UNC x 0.63 DP.	1	1/8	NO	011	NP
3.60	1.50	3.60	2.40	3.40	5/16-18 UNC x 0.44 DP.	2	1/8	NO	013	
4.60	2.20	7.10	4.10	4.10	3/8-16 UNC x 0.50 DP.	2	1/8	NO	007	NP
4.60	4.00	10.50	4.10	4.10	1/2-13 UNC x 0.63 DP.	1	1/8	NO	008	
5.60	4.00	9.50	5.10	5.10	1/2-13 UNC x 0.63 DP.	1	1/8	NO	005	NP
5.60	4.00	10.50	5.10	5.10	1/2-13 UNC x 0.63 DP.	1	1/8	NO	006	
5.60	2.20	6.25	5.10	5.10	3/8-16 UNC x 0.50 DP.	2	1/8	NO	010	
6.80	4.10	10.90	6.30	6.30	*M20-2.5-6g x 10 mm Long	1	1/8	NO	023	NP

Imperial Rolling Lobe Type

ENVELOPE DIMENSIONS			MOUNTING DIMENSIONS			FEATURES			Assembly Number	Flex Member Material
Maximum Diameter @ 100 psi (in.)	Compressed Height (in.)	Maximum Height (in.)	A Upper End Plate Diam. (in.)	B Lower End Plate Diam. (in.)	D Blind Tap for Mounting (in.)	End Retainer Style	Air Fitting Port (NPTF)	Internal Bumper		
8.70	5.60	18.60						NO	005	NR
8.70	6.80	18.60						YES	009	
9.50	5.60	17.90						NO	003	NR
9.50	3.20	11.80						NO	009	
11.00	6.00	20.10						NO	089	NR
11.50	3.70	13.00						NO	028	NR
11.70	6.10	17.10						YES	039	
12.70	7.70	21.10						YES	092	NR
12.70	4.40	13.50						YES	095	
12.70	9.50	27.00						YES	103	
12.90	6.10	16.90						YES	132	
12.60	9.50	29.10						YES	256	
12.80	8.10	22.80						YES	274	
14.60	8.90	25.80						YES	019	NR
14.60	7.70	22.50						YES	018	
14.80	5.70	18.00						YES	037	

FOR ROLLING LOBE TYPE AIR SPRINGS:
CONTACT YOUR LOCAL REPRESENTATIVE OR ENIDINE FOR MOUNTING AND AIR FITTING DIMENSIONS.

NOTE: NP= Neoprene
NR= Natural Rubber



Sleeve Type



Rolling Lobe Type

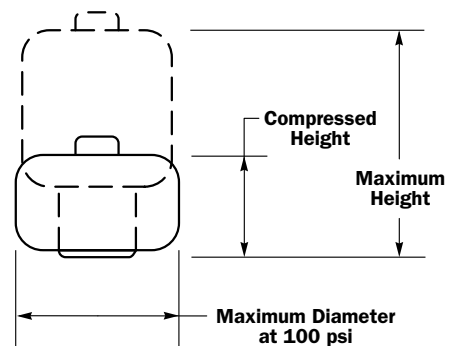

Bead Ring Style Overview

Enidine's large, Bead-Ring Style Air Springs are highly durable, precisely engineered and cost effective for use in a wide variety of actuation and vibration isolation applications. With time-tested designs, fabric-reinforced natural rubber flex member construction and corrosion-protected bead-ring mounting hardware, Enidine Air Springs provide superior quality and performance.

As an actuator, Enidine Air Springs provide linear or angular motion. These Air Springs offer a favorable stroke-to-compressed-height ratio when compared to air cylinders, and can accept a wide variety of actuation media such as air, water, nitrogen or anti-freeze.

As an isolator, Enidine Air Springs are effective in reducing the harmful effects of vibration. They can simultaneously isolate vibration and regulate load height, as well as allow for consistent vibration isolation under varying loads.

Enidine offers a variety of Air Spring types in addition to the large, Bead-Ring Style to meet your actuation or isolation needs. The Single, Double and Triple Convolute Bellows, Rolling Lobe and Sleeve Types are available in a wide range of sizes, with various end retainer mounting styles for your installation. Contact Enidine for further information regarding these Air Spring products.

Temperature Range Guidelines

Enidine Bead-Ring Style Air Springs are constructed of natural rubber. The standard operating temperature is from -40°F (-40°C) to 125°F (50°C). The maximum permissible operating temperature is 160°F (70°C), although when operating at this temperature, the air spring may have a reduced service life.

Storage

Enidine Air Springs should be stored in dark, dry conditions at normal room temperature.

Chemical Resistance

Enidine Air Springs are resistant to:

- Compressed air containing oil
- Chemically non-aggressive dust and contaminant's
- Alkaline and acidic cleaning agents
- Glycol-based hydraulic fluids
- The effects of weathering

Installation Guidelines

Warning:

- Before installing, check the Air Spring carefully for any damage it may have suffered from transport or improper storage.
- Do not inflate the Air Spring until it has been secured properly.
- The maximum operating air pressure is 120 psi (8 bar).
- Upper and lower bead rings are attached by bolting each to the customer's own mounting plate. Bead-Ring Air Springs are provided with 3/8 – 24 UNF X 1 7/8 long bolts. Recommended torque is 28-32 FT-LBS.
- Customer will need to fabricate their own mounting plates. Plates must be flat with a minimum surface finish of 32 Ra (micro inches).
- Fully deflate the Air Spring before removing
- Provide stroke limitations to prevent the Air Spring from exceeding the maximum allowable stroke height and minimum compressed height.
- Never use the Air Spring in torsion.

Note: Products contained in this publication are manufactured for Enidine Incorporated by ContiTech, a division of Continental AG.

The contents of this publication are the result of many years of research and experience gained in application technology. All information is given in good faith; it does not represent a guarantee with respect to characteristics and does not exempt the user from testing the suitability of products, including checking with respect to industrial property rights of any third parties. No liability whatsoever will be accepted for damage, regardless of its nature and its legal basis, arising from advice given in this publication. Products are subject to technical changes as a result of new developments.

Bead Ring Applications and Other Uses

Applications

- Paper & pulp mill equipment
- Stamping press cushions in automotive plants
- Laminate press equipment
- Large material handling equipment - Heavy Industry



Other Uses

- Use as a protective boot or flexible coupling
- Stack multiple airsprings together for increased stroke capabilities
- Use when the application requires a rapid flow of air in and out of the air spring

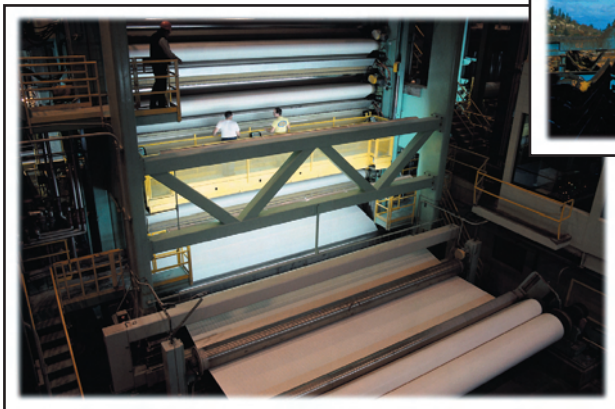

Single Convoluted Air Spring

YI-FS 960-12-478

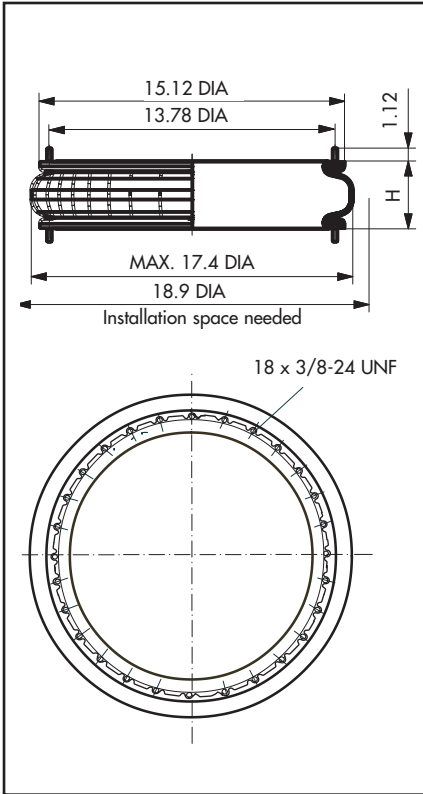

Force-Height-diagram

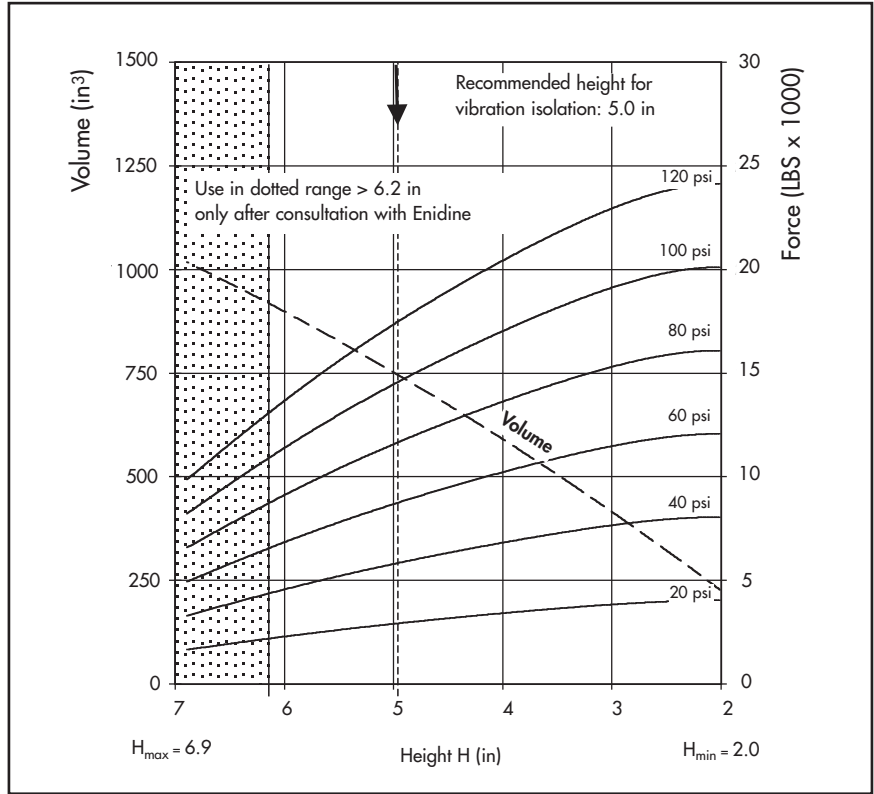

Purchase Order Data

Type	Part Number
Bellows with bead rings, 1 7/8 bolts, nuts and washers	YI-FS 960-12-478
Rubber bellows only	YR-FS 960-12-119

Additional types on request

Service Instruction:
3/8-24 UNF = 28-32 FT-LBS

Technical Data

Min. Pressure	0 psi
Return Force to min. height	≤ 22 lbs
Overall weight with bead rings, bolts, nuts and washers	11 lbs

Vibration Isolation - dynamic characteristic values

Design height H: recommended 5 in, minimum 4.3 in

Pressure p (psi)	40	60	80	100	120	Vol. V (in³)
Force (Load) (lbs)	5780	8660	11550	14440	17330	754
Spring Rate (lbs/in)	3123	4529	5820	7176	8580	
Natural Frequency (Hz)	2.2	2.2	2.2	2.2	2.2	

Pneumatic Application - static characteristic values

Force F (lbs)

Pressure p (psi)	20	40	60	80	100	120	Vol. (in³)
Height H (in)	6	2280	4570	6850	9130	11420	892
	5.5	2610	5210	7820	10430	13040	822
	5	2890	5780	8660	11550	14440	754
	4.5	3150	6300	9450	12600	15750	675
	4	3390	6780	10170	13570	16960	591
	3.5	3640	7270	10910	14550	18180	500
	3	3820	7640	11460	15280	19100	412

Single Convoluted Air Spring

YI-FS 1330-11-197

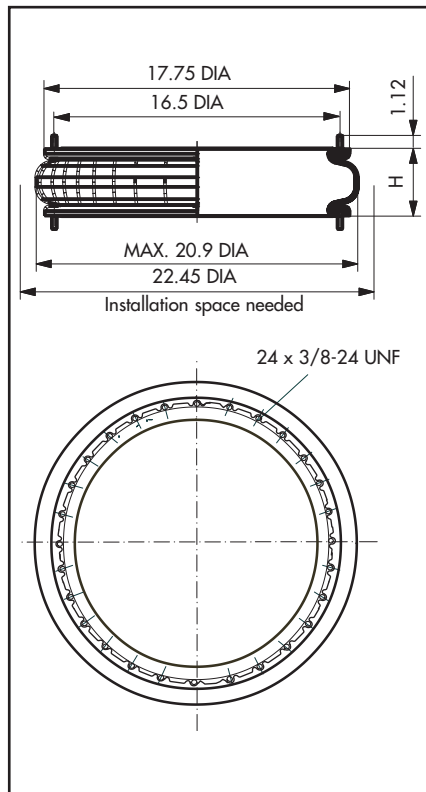

Force-Height-diagram

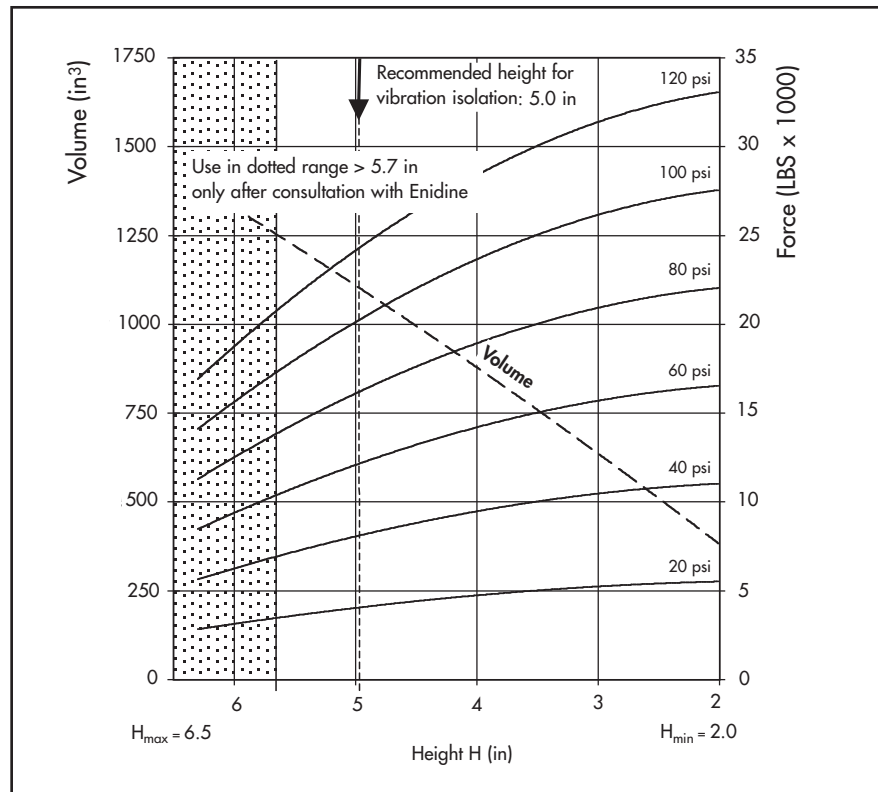

Purchase Order Data

Type	Part Number
Bellows with bead rings, 1 7/8 bolts, nuts and washers	YI-FS 1330-11-197
Rubber bellows only	YR-FS 1330-11-135

Additional types on request

Service Instruction:
3/8-24 UNF = 28-32 FT-LBS

Technical Data

Min. Pressure	0 psi
Return Force to min. height	≤ 20 lbs
Overall weight with bead rings, bolts, nuts and washers	16.1 lbs

Vibration Isolation - dynamic characteristic values

Design height H: recommended 5.0 in, minimum 4.1 in

Pressure p (psi)	40	60	80	100	120	Vol. V (in³)
Force (Load) (lbs)	8040	12060	16080	20100	24120	1114
Spring Rate (lbs/in)	4268	6218	8025	9932	11722	
Natural Frequency (Hz)	2.2	2.2	2.2	2.2	2.2	

Pneumatic Application - static characteristic values

Force F (lbs)

Pressure p (psi)	20	40	60	80	100	120	Vol. (in³)
Height H (in)	5.5	3620	7230	10850	14470	18080	1224
	5	4020	8040	12060	16080	20100	1112
	4.5	4370	8740	13110	17480	21850	994
	4	4720	9440	14150	18870	23590	871
	3.5	5010	10030	15040	20050	25060	766
	3	5240	10480	15720	20970	26210	632

Single Convoluted Air Spring

YI-FS 1710-12-727

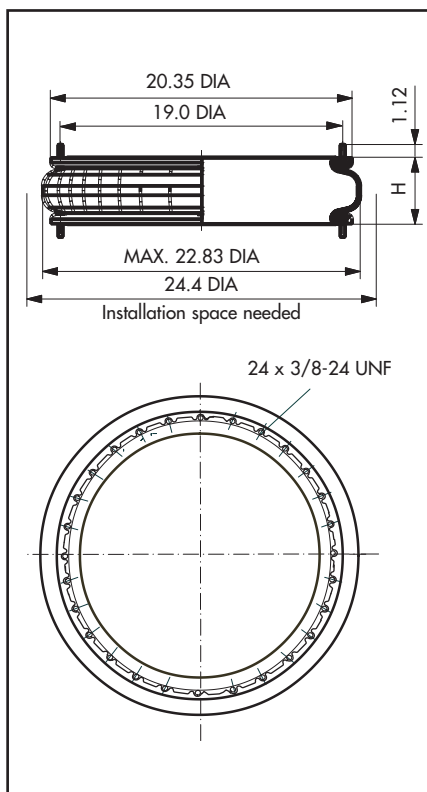

Force-Height-diagram

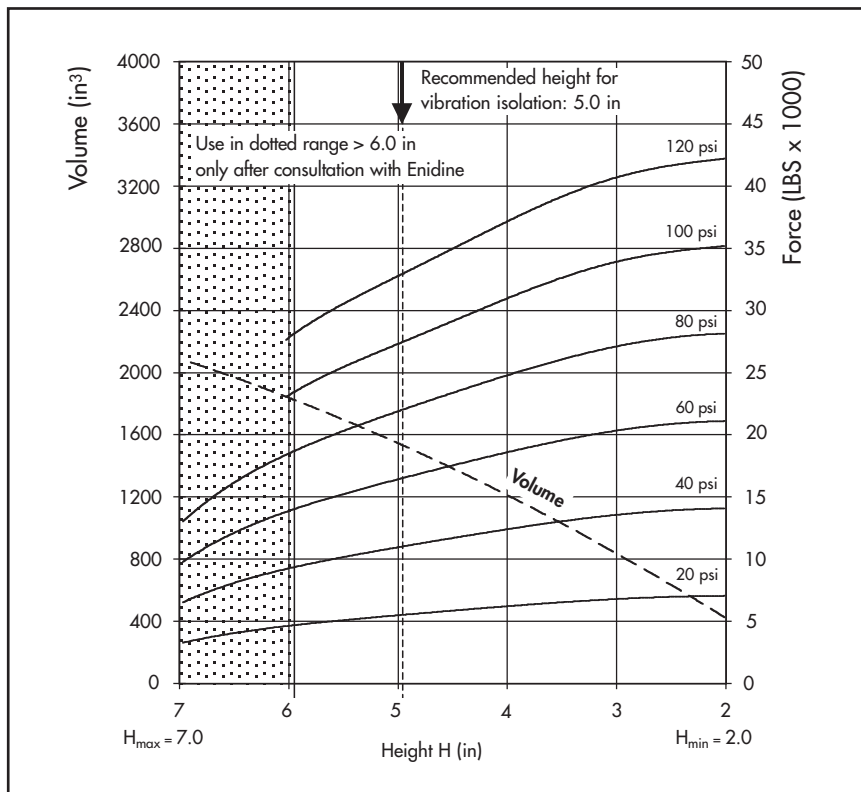

Purchase Order Data

Type	Part Number
Bellows with bead rings, 1 7/8 bolts, nuts and washers	YI-FS 1710-12-727
Rubber bellows only	YR-FS 1710-12-726

Additional types on request

Service Instruction:
3/8-24 UNF = 28-32 FT-LBS

Technical Data

Min. Pressure	0 psi
Return Force to min. height	≤ 27 lbs
Overall weight with bead rings, bolts, nuts and washers	19.2 lbs

Vibration Isolation - dynamic characteristic values

Design height H: recommended 5 in, minimum 4.3 in

Pressure p (psi)	40	60	80	100	120	Vol. V (in³)
Force (Load) (lbs)	10900	16350	21800	27250	32700	
Spring Rate (lbs/in)	5349	7606	9770	12114	14456	
Natural Frequency (Hz)	2.2	2.2	2.1	2.1	2.1	

Pneumatic Application - static characteristic values

Force F (lbs)

Pressure p (psi)	20	40	60	80	100	120	Vol. (in³)
Height H (in)	6	4620	9250	13870	18500	23120	1836
	5	5450	10900	16350	21800	27250	1544
	4	6190	12390	18580	24780	30970	1195
	3	6760	13510	20270	27020	33780	842

Single Convoluted Air Spring

YI-FS 2870-16-737

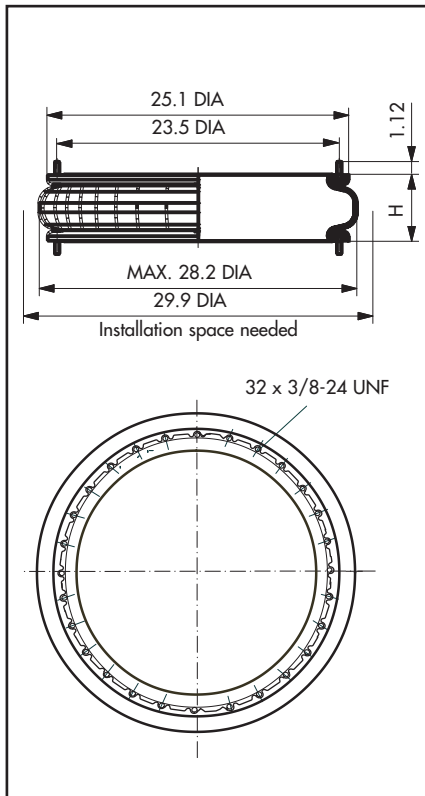

Force-Height-diagram

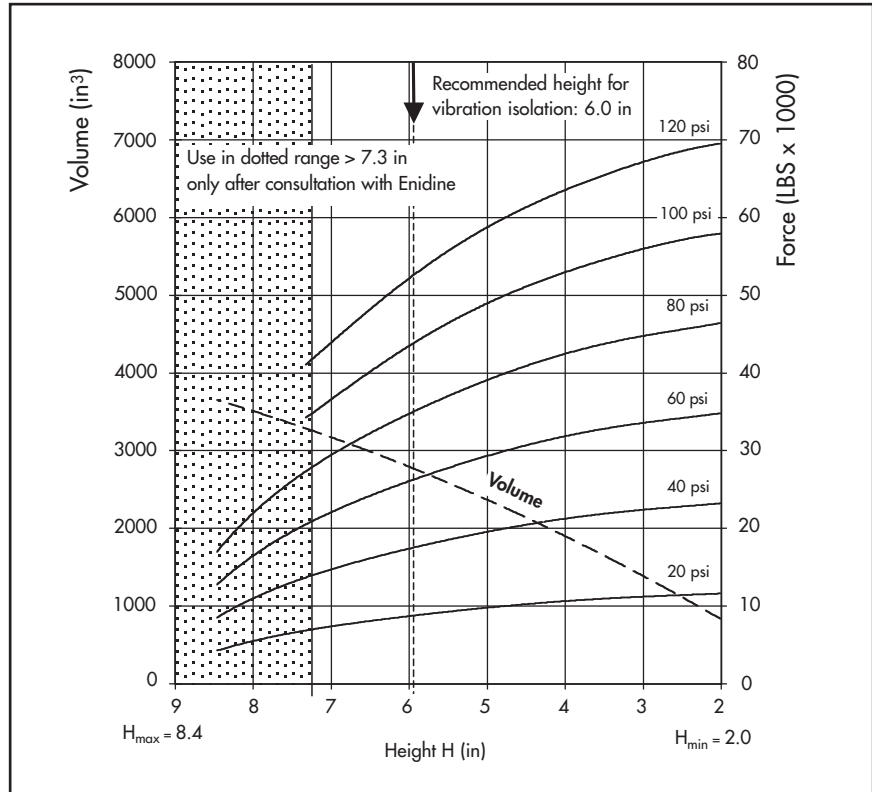

Purchase Order Data

Type	Part Number
Bellows with bead rings, 1 7/8 bolts, nuts and washers	YI-FS 2870-16-737
Rubber bellows only	YR-FS 2870-16-147

Additional types on request

Service Instruction:
3/8-24 UNF = 28-32 FT-LBS

Technical Data

Min. Pressure	0 psi
Return Force to min. height	≤ 151 lbs
Overall weight with bead rings, bolts, nuts and washers	24.5 lbs

Vibration Isolation - dynamic characteristic values

Design height H: recommended 6.0 in, minimum 5.1 in

Pressure p (psi)	40	60	80	100	120	Vol. V (in ³)
Force (Load) (lbs)	17290	25940	34580	43230	51870	2797
Spring Rate (lbs/in)	7380	10405	13461	16000	18543	
Natural Frequency (Hz)	2.0	2.0	1.9	1.9	1.9	

Pneumatic Application - static characteristic values

Force F (lbs)

Pressure p (psi)	20	40	60	80	100	120	Vol. (in ³)	
Height H (in)	7	7340	14680	22020	29370	36710	44050	3173
	6	8650	17290	25940	34580	43230	51870	2797
	5	9790	19570	29360	39140	48930	58720	2371
	4	10560	21130	31690	42250	52820	63380	1865
	3	11160	22330	33490	44650	55810	66980	1364

Single Convoluted Air Spring

YI-FS 5450-16-601

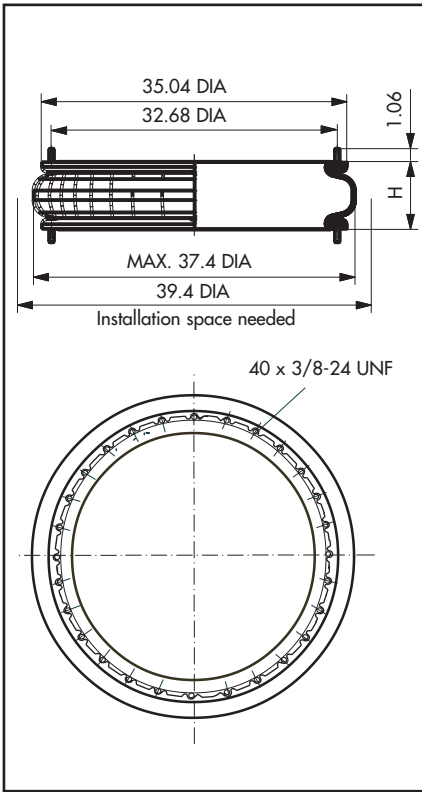

Force-Height-diagram

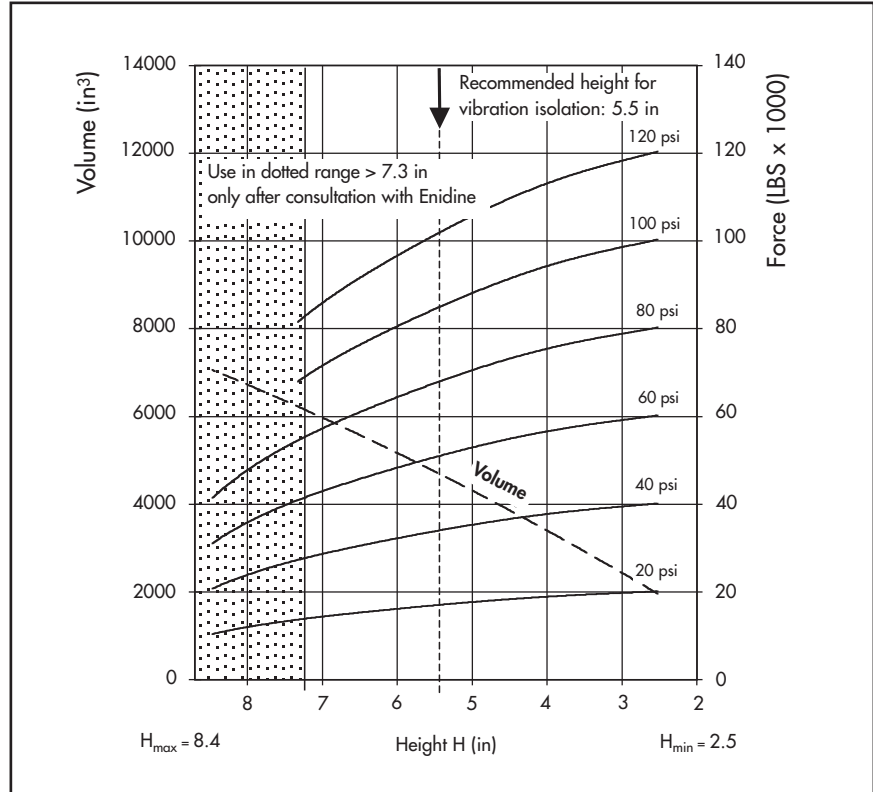

Purchase Order Data

Type	Part Number
Bellows with bead rings, 1 7/8 bolts, nuts and washers	YI-FS 5450-16-601
Rubber bellows only	YR-FS 5450-16-021

Additional types on request

Service Instruction:
3/8-24 UNF = 28-32 FT-LBS

Technical Data

Min. Pressure	0 psi
Return Force to min. height	≤ 310 lbs
Overall weight with bead rings, bolts, nuts and washers	48.5 lbs

Vibration Isolation - dynamic characteristic values

Design height H: recommended 5.5 in, minimum 4.7 in

Pressure p (psi)	40	60	80	100	120	Vol. V (in ³)
Force (Load) (lbs)	33810	50720	67630	84530	101440	4713
Spring Rate (lbs/in)	13532	19511	25290	30229	35739	
Natural Frequency (Hz)	2.0	2.0	1.9	1.9	1.9	

Pneumatic Application - static characteristic values

Force F (lbs)

Pressure p (psi)	20	40	60	80	100	120	Vol. (in ³)
Height H (in)	7	14280	28570	42850	57140	71420	6006
	6	16080	32160	48240	64320	80400	5162
	5	17580	35150	52730	70310	87890	4271
	4	18850	37710	56560	75410	94270	3410
	3	19710	39420	59130	78840	98550	2412

Double Convoluted Air Spring

YI-FD 960-22-191

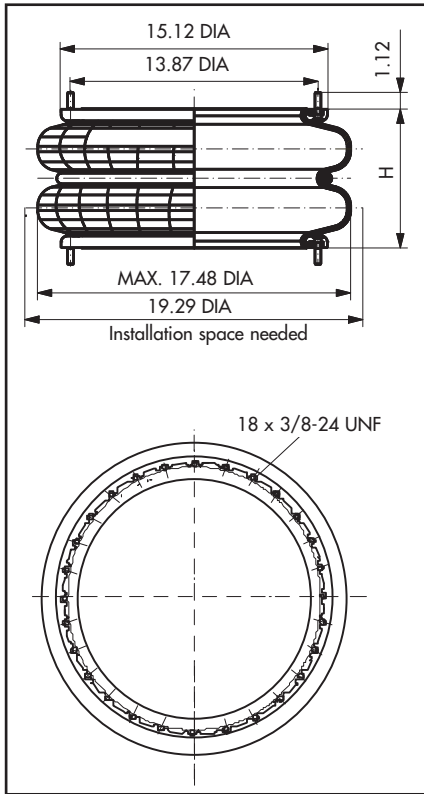

Force-Height-diagram

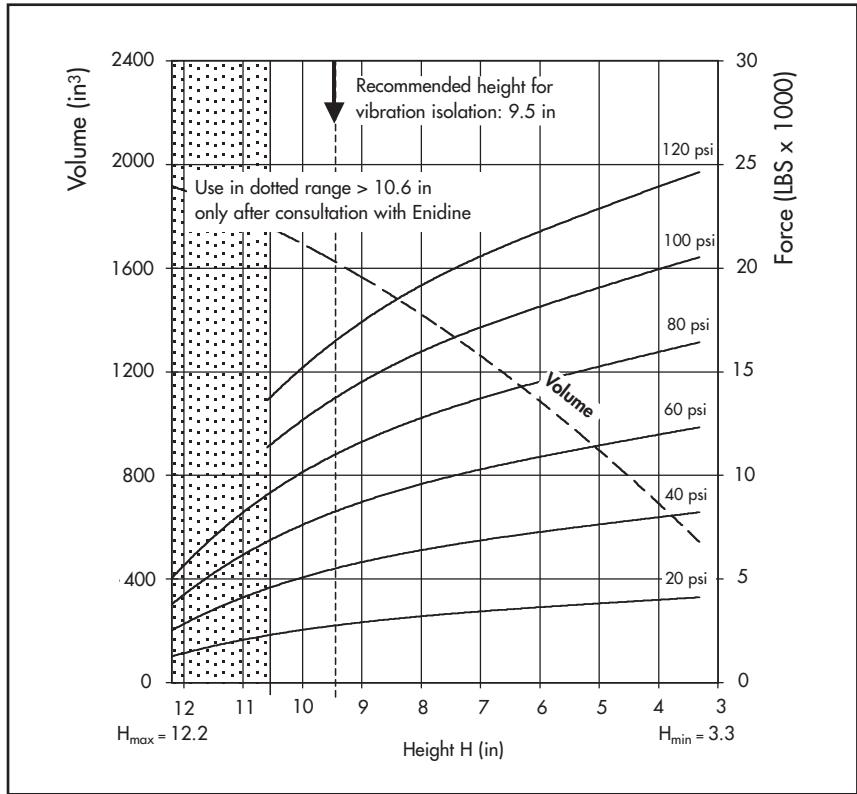

Purchase Order Data

Type	Part Number
Bellows with bead rings, 1 7/8 bolts, nuts and washers	YI-FD 960-22-191
Rubber bellows only	YR-FD 960-22-925

Additional types on request

Service Instruction:
3/8-24 UNF = 28-32 FT-LBS

Technical Data

Min. Pressure	0 psi
Return Force to min. height	≤ 45 lbs
Overall weight with bead rings, bolts, nuts and washers	19 lbs

Vibration Isolation - dynamic characteristic values

Design height H: recommended 9.5 in, minimum 8.7 in

Pressure p (psi)	40	60	80	100	120	Vol. V (in ³)
Force (Load) (lbs)	5450	8180	10900	13630	16350	1655
Spring Rate (lbs/in)	1638	2303	3005	3633	4317	
Natural Frequency (Hz)	1.7	1.7	1.6	1.6	1.6	

Pneumatic Application - static characteristic values

Force F (lbs)

Pressure p (psi)	20	40	60	80	100	120	Vol. (in ³)
Height H (in)	10	2520	5040	7560	10080	12600	1687
	9	2890	5790	8680	11580	14470	1566
	8	3190	6380	9560	12750	15940	1423
	7	3420	6840	10260	13680	17100	1265
	6	3630	7260	10890	14510	18140	1081
	5	3800	7610	11410	15220	19020	896
	4	3990	7980	11970	15960	19950	688

Double Convoluted Air Spring

YI-FD 1330-25-227

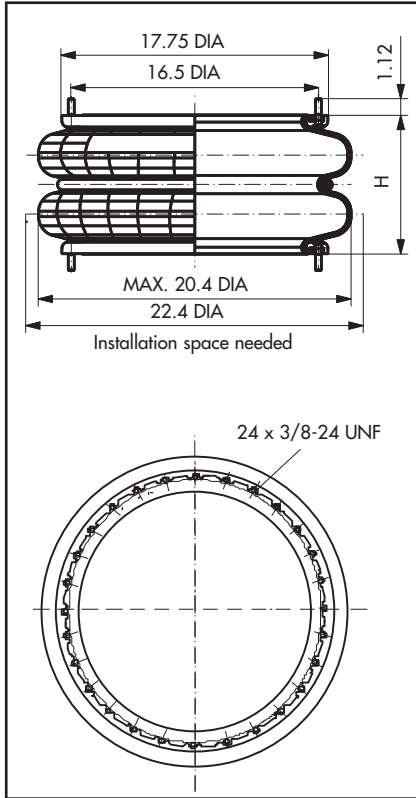

Force-Height-diagram

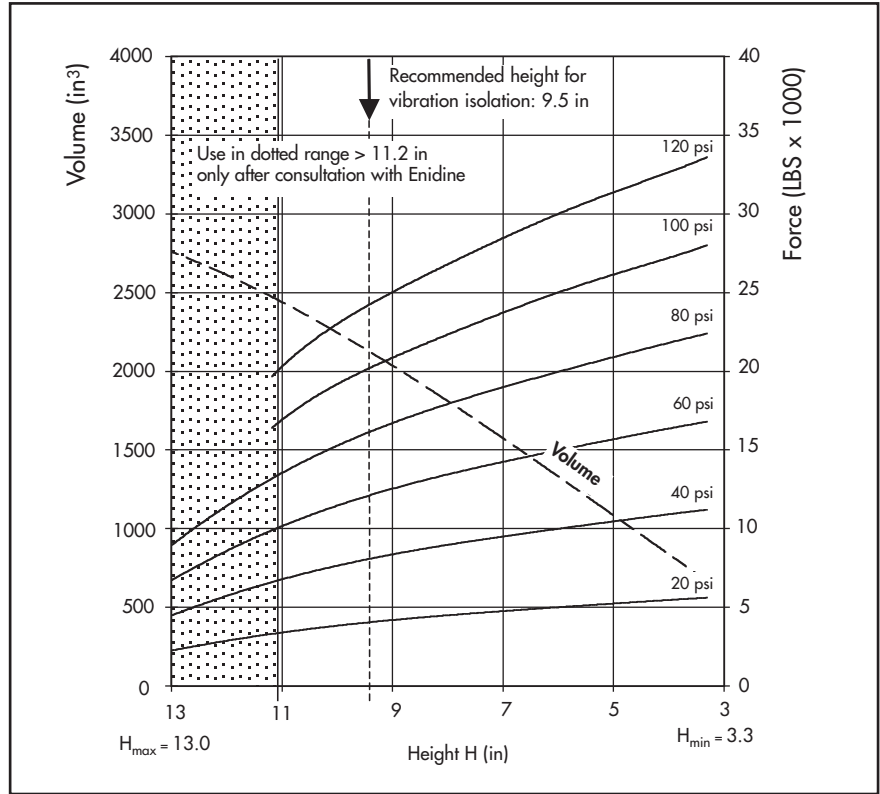

Purchase Order Data

Type	Part Number
Bellows with bead rings, 1 7/8 bolts, nuts and washers	YI-FD 1330-25-227
Rubber bellows only	YR-FD 1330-25-205

Additional types on request

Service Instruction:
3/8-24 UNF = 28-32 FT-LBS

Technical Data

Min. Pressure	0 psi
Return Force to min. height	≤ 40 lbs
Overall weight with bead rings, bolts, nuts and washers	23.8 lbs

Vibration Isolation - dynamic characteristic values

Design height H: recommended 9.5 in, minimum 8.7 in

Pressure p (psi)	40	60	80	100	120	Vol. V (in³)
Force (Load) (lbs)	7990	11990	15990	19980	23980	2145
Spring Rate (lbs/in)	2173	3171	4101	4915	5882	
Natural Frequency (Hz)	1.6	1.6	1.5	1.5	1.5	

Pneumatic Application - static characteristic values

Force F (lbs)

Pressure p (psi)	20	40	60	80	100	120	Vol. (in³)
Height H (in)	11	3360	6710	10070	13430	16780	2440
	10	3930	7860	11790	15720	19650	2236
	9	4180	8360	12550	16730	20910	2050
	8	4470	8930	13400	17870	22330	1821
	7	4760	9510	14270	19030	23780	1565
	6	4980	9970	14950	19930	24910	1334
	5	5220	10440	15660	20880	26100	1083

Double Convoluted Air Spring

YI-FD 1710-25-203

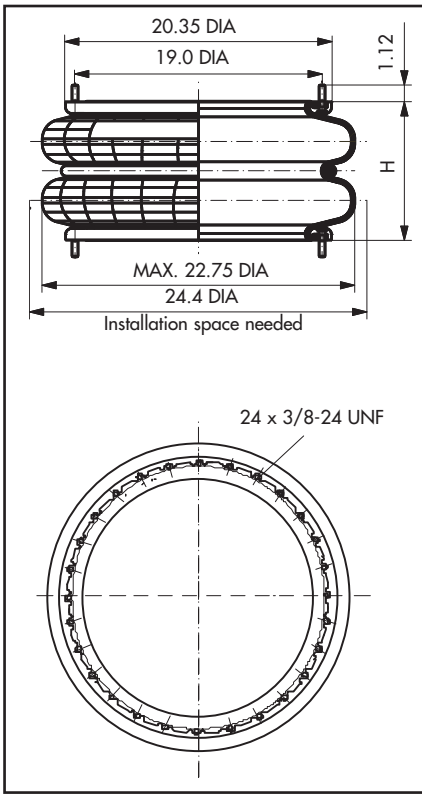

Force-Height-diagram

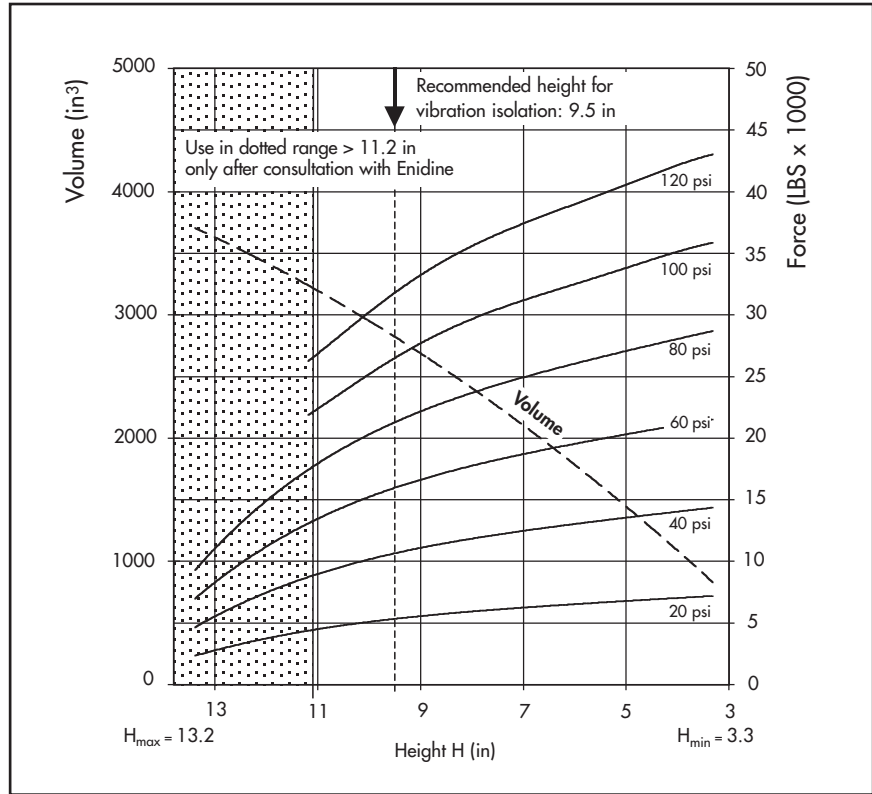

Purchase Order Data

Type	Part Number
Bellows with bead rings, 1 7/8 bolts, nuts and washers	YI-FD 1710-25-203
Rubber bellows only	YR-FD 1710-25-902

Additional types on request

Service Instruction:
3/8-24 UNF = 28-32 FT-LBS

Technical Data

Min. Pressure	0 psi
Return Force to min. height	≤ 70 lbs
Overall weight with bead rings, bolts, nuts and washers	26.5 lbs

Vibration Isolation - dynamic characteristic values

Design height H: recommended 9.5 in, minimum 8.7 in

Pressure p (psi)	40	60	80	100	120	Vol. V (in³)
Force (Load) (lbs)	10580	15860	21150	26440	31730	2820
Spring Rate (lbs/in)	2814	4027	5266	6299	7417	
Natural Frequency (Hz)	1.6	1.6	1.6	1.5	1.5	

Pneumatic Application - static characteristic values

Force F (lbs)

Pressure p (psi)	20	40	60	80	100	120	Vol. (in³)
Height H (in)	10	5020	10040	15050	20070	25090	2943
	8	5920	11840	17760	23680	29600	2407
	6	6490	12990	19480	25970	32460	1781
	4	7010	14020	21020	28030	35040	1076

Double Convoluted Air Spring

YI-FD 2380-24-772

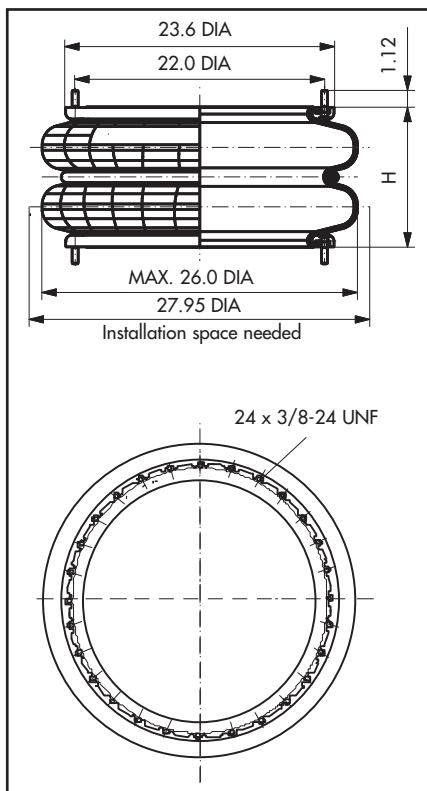

Force-Height-diagram

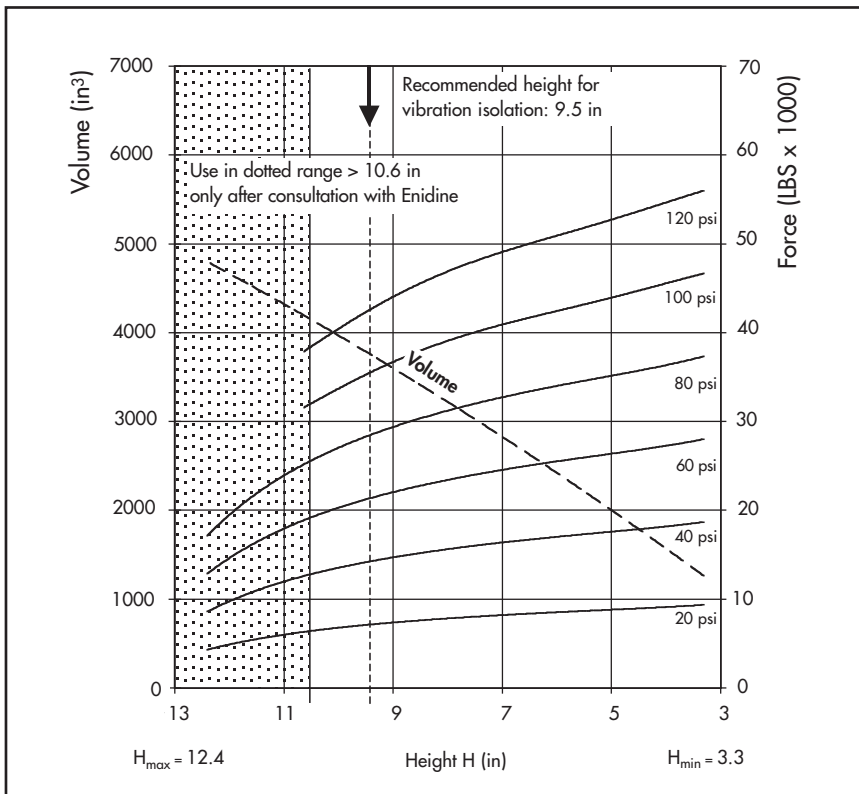

Purchase Order Data

Type	Part Number
Bellows with bead rings, 1 7/8 bolts, nuts and washers	YI-FD 2380-24-772
Rubber bellows only	YR-FD 2380-24-126

Additional types on request

Service Instruction:
3/8-24 UNF = 28-32 FT-LBS

Technical Data

Min. Pressure	0 psi
Return Force to min. height	≤100 lbs
Overall weight with bead rings, bolts, nuts and washers	31 lbs

Vibration Isolation - dynamic characteristic values

Design height H: recommended 9.5 in, minimum 8.7 in

Pressure p (psi)	40	60	80	100	120	Vol. V (in³)
Force (Load) (lbs)	14090	21130	28180	35220	42260	
Spring Rate (lbs/in)	3790	5344	7004	8391	10009	
Natural Frequency (Hz)	1.6	1.6	1.6	1.5	1.5	

Pneumatic Application - static characteristic values

Force F (lbs)

Pressure p (psi)	20	40	60	80	100	120	Vol. (in³)	
Height H (in)	10	6730	13470	20200	26930	33670		3968
	9	7310	14620	21930	29240	36550		3602
	8	7830	15650	23480	31300	39130		3223
	7	8160	16310	24470	32620	40780		2836
	6	8480	16970	25450	33940	42420		2407
	5	8780	17560	26350	35130	43910		1989
	4	9100	18210	27310	36420	45520		1567

Double Convoluted Air Spring

YI-FD 2870-30-230

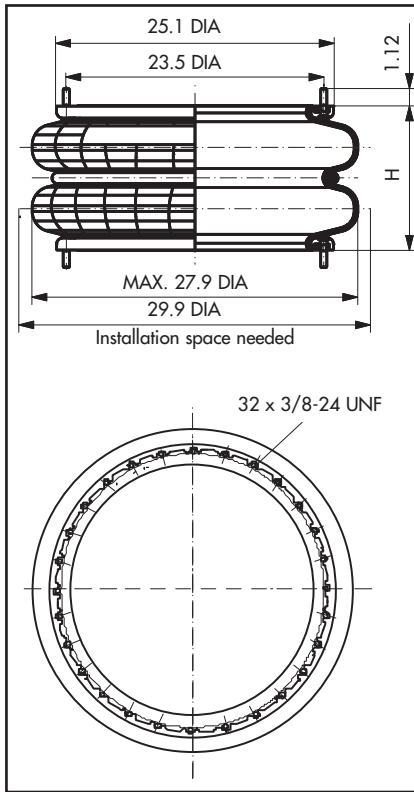

Force-Height-diagram

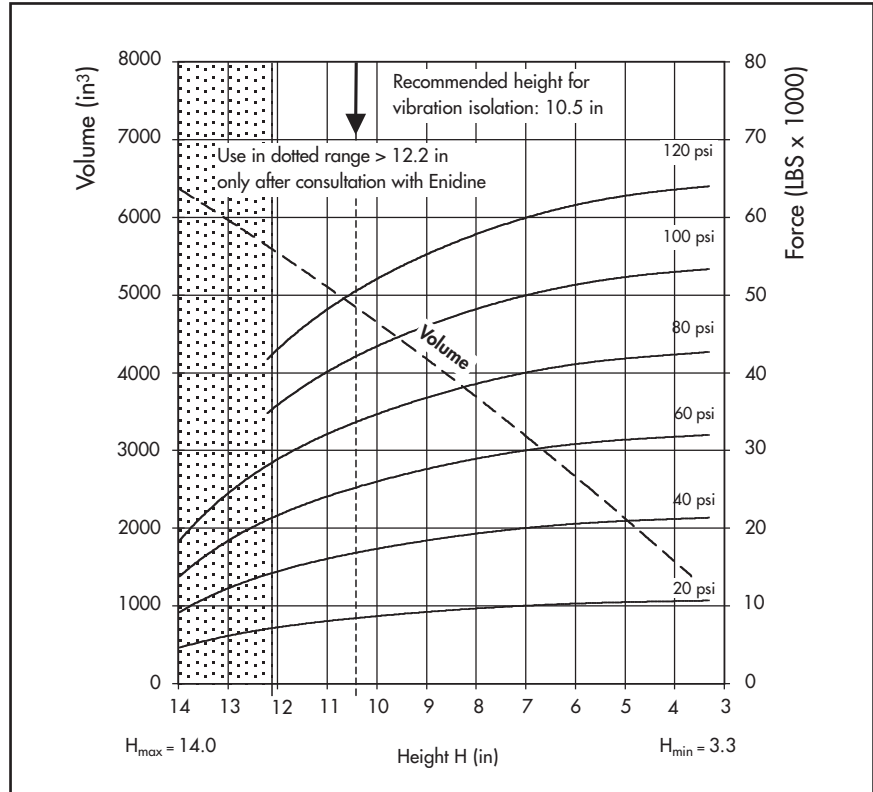

Purchase Order Data

Type	Part Number
Bellows with bead rings, 1 7/8 bolts, nuts and washers	YI-FD 2870-30-230
Rubber bellows only	YR-FD 2870-30-912

Additional types on request

Service Instruction:
3/8-24 UNF = 28-32 FT-LBS

Technical Data

Min. Pressure	0 psi
Return Force to min. height	≤ 157 lbs
Overall weight with bead rings, bolts, nuts and washers	34 lbs

Vibration Isolation - dynamic characteristic values

Design height H: recommended 10.5 in, minimum 9.6 in

Pressure p (psi)	40	60	80	100	120	Vol. V (in ³)
Force (Load) (lbs)	16700	25050	33400	41750	50100	4884
Spring Rate (lbs/in)	4058	5817	7420	8734	10452	
Natural Frequency (Hz)	1.5	1.5	1.5	1.4	1.4	

Pneumatic Application - static characteristic values

Force F (lbs)

Pressure p (psi)	20	40	60	80	100	120	Vol. (in ³)	
Height H (in)	12	7130	14270	21400	28540	35670	42810	5521
	10	8640	17290	25930	34570	43210	51860	4647
	8	9640	19280	28930	38570	48210	57850	3702
	6	10230	20460	30690	40920	51150	61370	2657
	4	10590	21170	31760	42340	52930	63510	1549

Double Convoluted Air Spring

YI-FD 5450-28-602

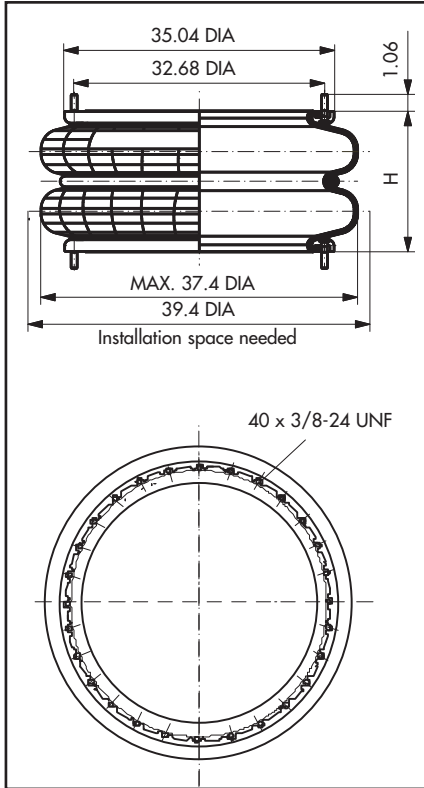

Force-Height-diagram

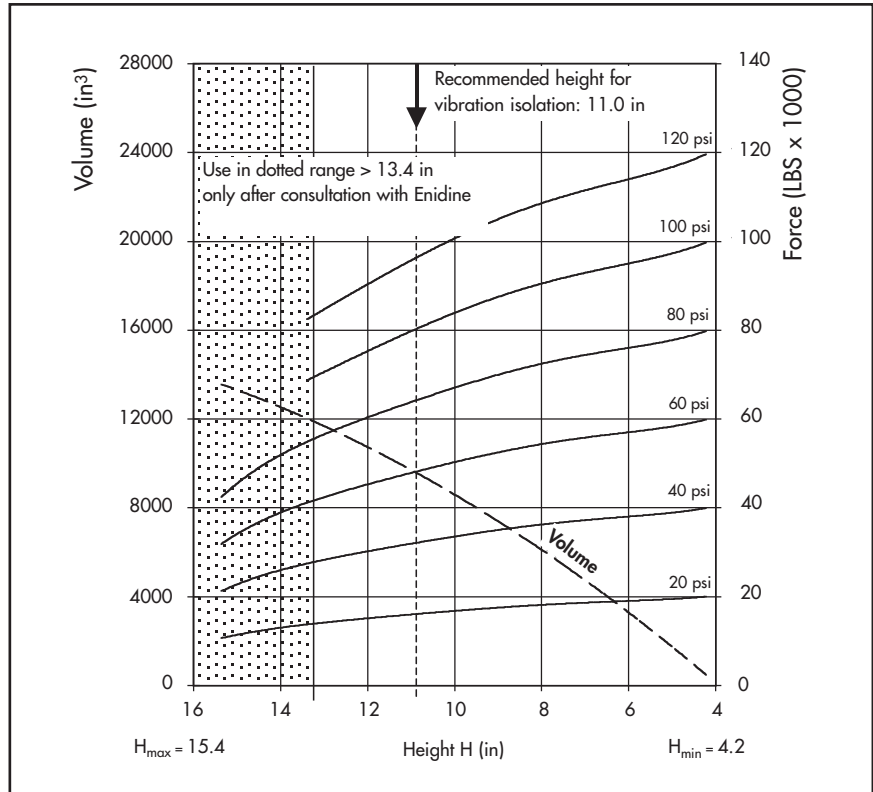

Purchase Order Data

Type	Part Number
Bellows with bead rings, 1 7/8 bolts, nuts and washers	YI-FD 5450-28-602
Rubber bellows only	YR-FD 5450-28-022

Additional types on request

Service Instruction:

3/8-24 UNF = 28-32 FT-LBS

Technical Data

Min. Pressure	0 psi
Return Force to min. height	≤ 350 lbs
Overall weight with bead rings, bolts, nuts and washers	72.5 lbs

Vibration Isolation - dynamic characteristic values

Design height H: recommended 11 in, minimum 10.2 in

Pressure p (psi)	40	60	80	100	120	Vol. V (in ³)
Force (Load) (lbs)	31720	47590	63450	79310	95170	9577
Spring Rate (lbs/in)	6661	9336	12195	14533	17173	
Natural Frequency (Hz)	1.4	1.4	1.4	1.3	1.3	

Pneumatic Application - static characteristic values

Force F (lbs)

Pressure p (psi)	20	40	60	80	100	120	Vol. (in ³)
Height H (in)	13	14120	28240	42350	56470	70590	11677
	11	15860	31720	47590	63450	79310	9577
	9	17490	34990	52480	69980	87470	7385
	7	18520	37040	55560	74080	92600	4788
	5	19530	39070	58600	78130	97660	1789

Triple Convoluted Air Spring

YI-FT 960-34-761

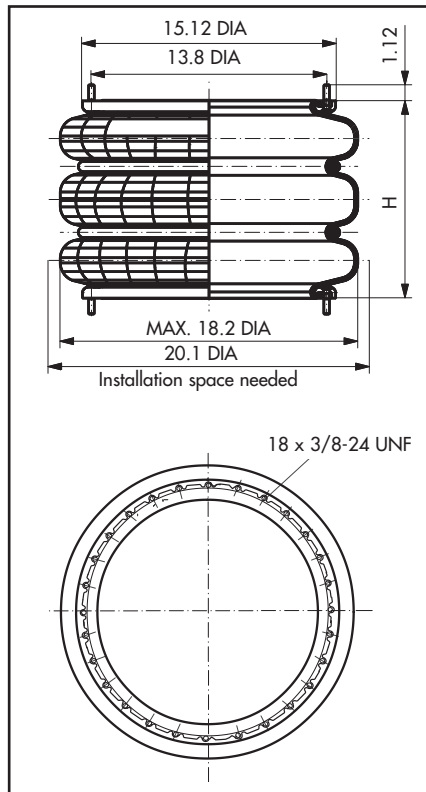

Force-Height-diagram

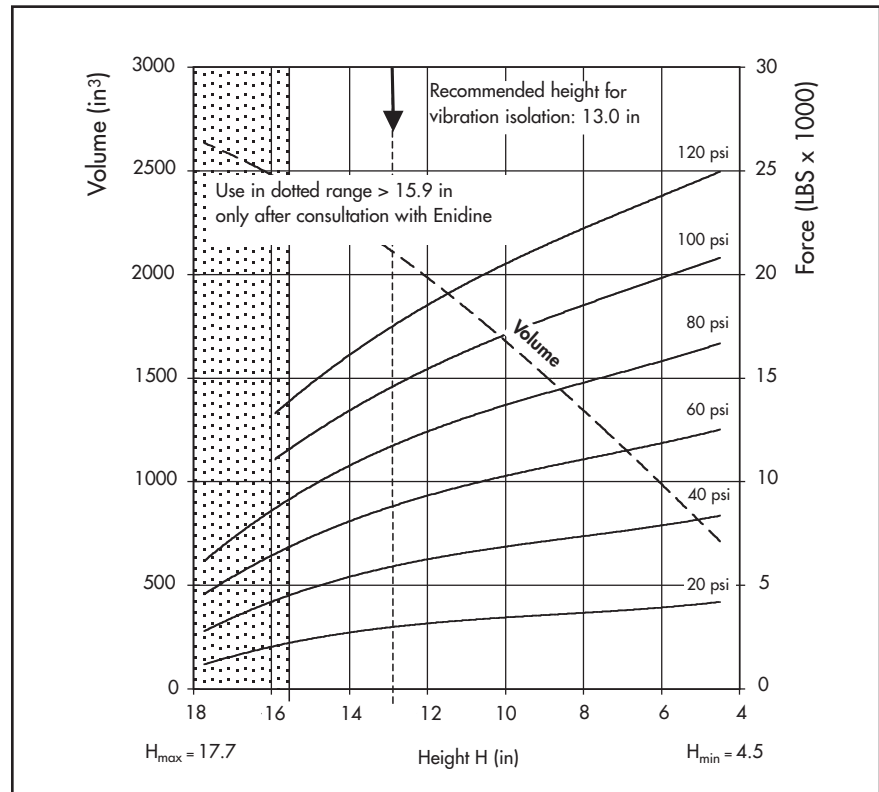

Purchase Order Data

Type	Part Number
Bellows with bead rings, 1 7/8 bolts, nuts and washers	YI-FT 960-34-761
Rubber bellows only	YR-FT 960-34-914

Additional types on request

Service Instruction:
3/8-24 UNF = 28-32 FT-LBS

Technical Data

Min. Pressure	0 psi
Return Force to min. height	≤135 lbs
Overall weight with bead rings, bolts, nuts and washers	21 lbs

Vibration Isolation - dynamic characteristic values

Design height H: recommended 13 in, minimum 12.4 in

Pressure p (psi)	40	60	80	100	120	Vol. V (in³)
Force (Load) (lbs)	5770	8650	11530	14420	17300	
Spring Rate (lbs/in)	1144	1659	2079	2610	3029	
Natural Frequency (Hz)	1.4	1.3	1.3	1.3	1.3	

Pneumatic Application - static characteristic values

Force F (lbs)

Pressure p (psi)	20	40	60	80	100	120	Vol. (in³)
Height H (in)	15	2420	4830	7250	9670	12080	2368
	13	2880	5770	8650	11530	14420	2125
	11	3270	6530	9800	13070	16330	1846
	9	3560	7130	10690	14250	17820	1511
	7	3830	7650	11480	15300	19130	1161

Triple Convoluted Air Spring

YI-FT 1330-35-823

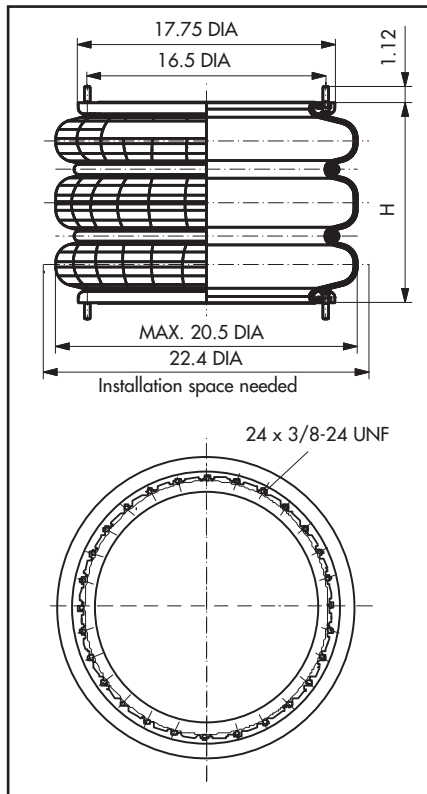

Force-Height-diagram

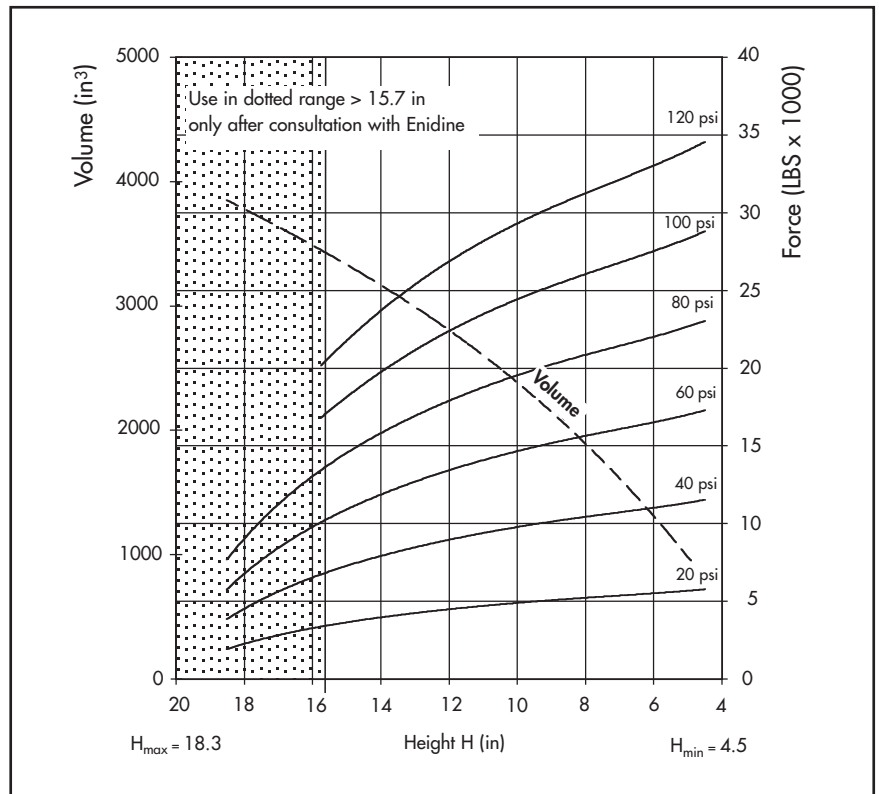

Purchase Order Data

Type	Part Number
Bellows with bead rings, 1 7/8 bolts, nuts and washers	YI-FT 1330-35-823
Rubber bellows only	YR-FT 1330-35-921

Additional types on request

Service Instruction:
3/8-24 UNF = 28-32 FT-LBS

Technical Data

Min. Pressure	0 psi
Return Force to min. height	≤ 70 lbs
Overall weight with bead rings, bolts, nuts and washers	27.6 lbs

Pneumatic Application - static characteristic values

Force F (lbs)

Pressure p (psi)	20	40	60	80	100	120	Vol. (in ³)
Height H (in)	15	3620	7240	10860	14480	18100	3321
	13	4240	8480	12730	16970	21210	2991
	11	4680	9360	14040	18720	23400	28080
	9	5050	10100	15150	20200	25250	30310
	7	5350	10710	16060	21410	26770	32120
5	5660	11330	16990	22660	28320	33980	950

Triple Convolted Air Spring

YI-FT 1710-38-324

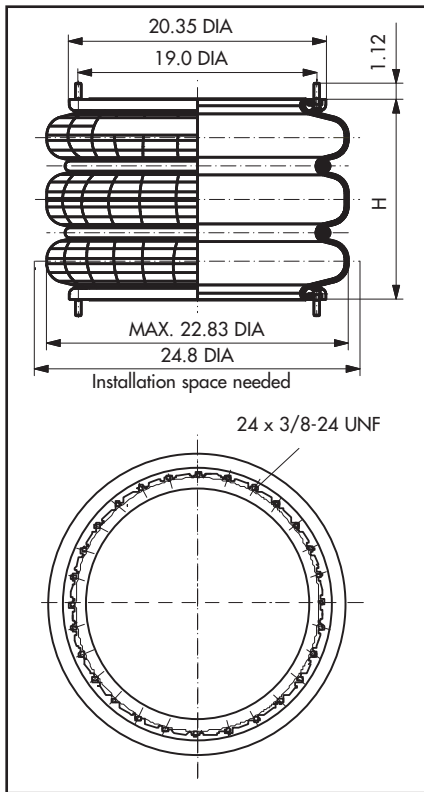

Force-Height-diagram

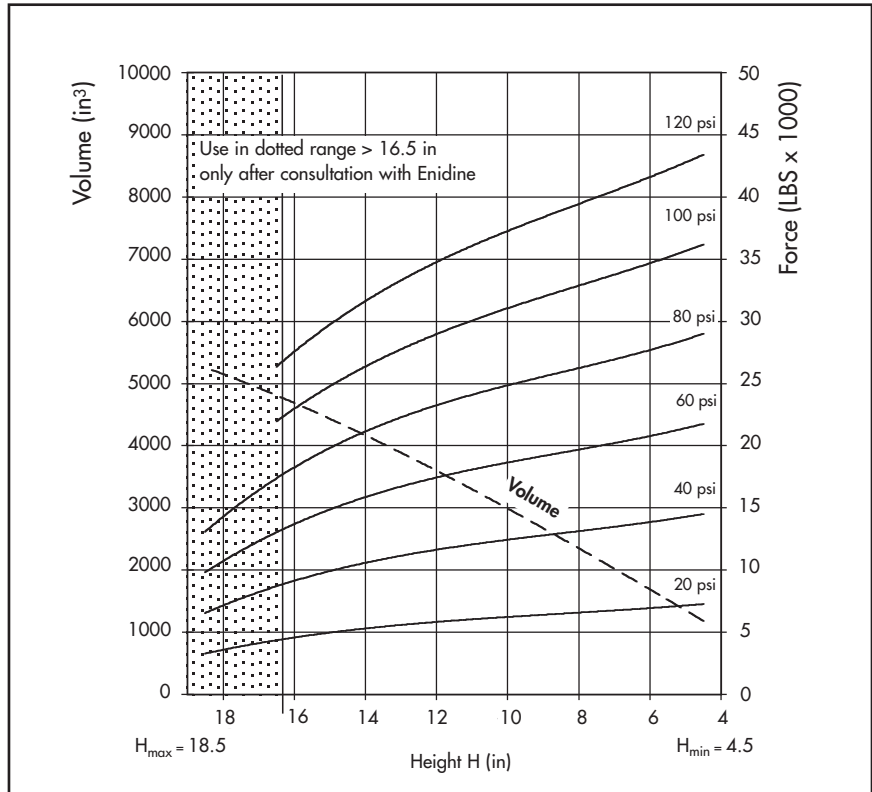

Purchase Order Data

Type	Part Number
Bellows with bead rings, 1 7/8 bolts, nuts and washers	YI-FT 1710-38-324
Rubber bellows only	YR-FT 1710-38-987

Additional types on request

Service Instruction:
3/8-24 UNF = 28-32 FT-LBS

Technical Data

Min. Pressure	0 psi
Return Force to min. height	≤ 90 lbs
Overall weight with bead rings, bolts, nuts and washers	32 lbs

Pneumatic Application - static characteristic values

Force F (lbs)

Pressure p (psi)	20	40	60	80	100	120	Vol. (in ³)	
Height H (in)	15	4940	9880	14820	19760	24700	29640	4419
	13	5550	11100	16660	22210	27760	33310	3907
	11	6010	12030	18040	24060	30070	36090	3285
	9	6360	12720	19090	25450	31810	38170	2668
	7	6750	13500	20260	27010	33760	40510	2029

Triple Convoluted Air Spring

YI-FT 2870-45-304

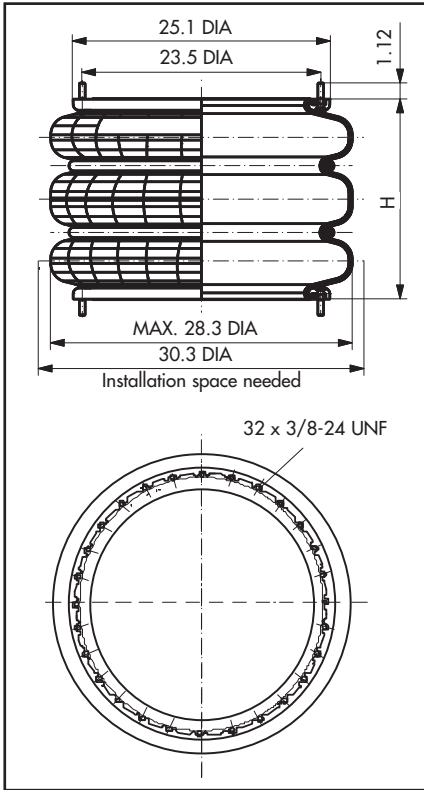

Force-Height-diagram

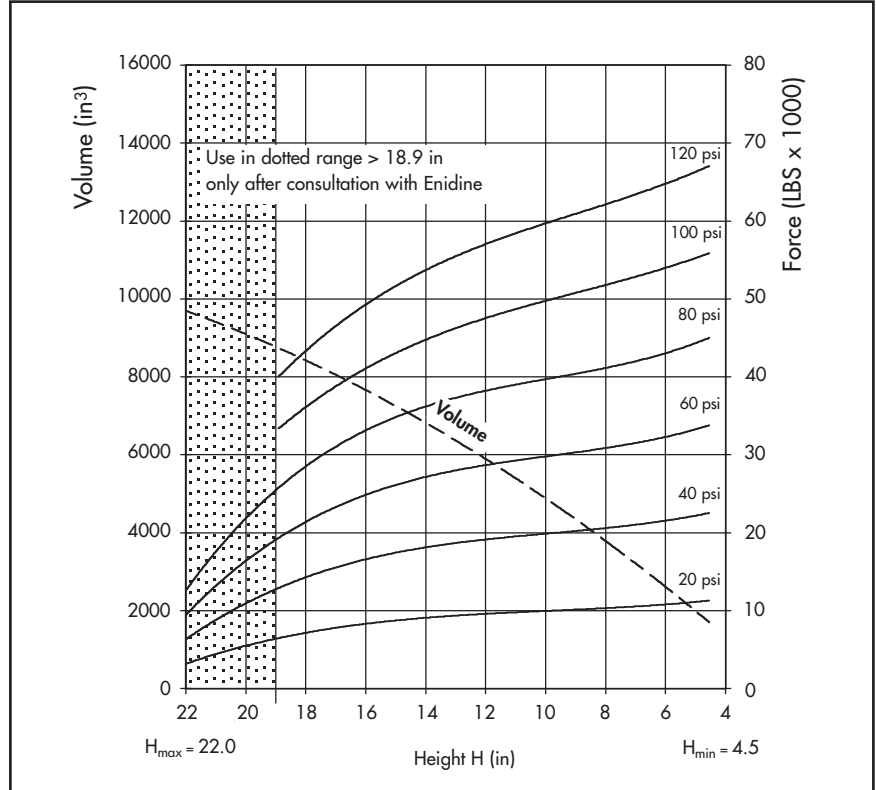

Purchase Order Data

Type	Part Number
Bellows with bead rings, 1 7/8 bolts, nuts and washers	YI-FT 2870-45-304
Rubber bellows only	YR-FT 2870-45-919

Additional types on request

Service Instruction:
3/8-24 UNF = 28-32 FT-LBS

Technical Data

Min. Pressure	0 psi
Return Force to min. height	≤ 180 lbs
Overall weight with bead rings, bolts, nuts and washers	38 lbs

Pneumatic Application - static characteristic values

Force F (lbs)

Pressure p (psi)	20	40	60	80	100	120	Vol. (in ³)
Height H (in)	18	7180	14370	21550	28730	35920	8500
	15	8580	17160	25750	34330	42910	7251
	12	9510	19010	28520	38020	47530	6015
	9	10120	20240	30360	40480	50590	4124
	6	10820	21640	32470	43290	54110	2440

Triple Convolted Air Spring

YI-FT 5450-44-603

Force-Height-diagram

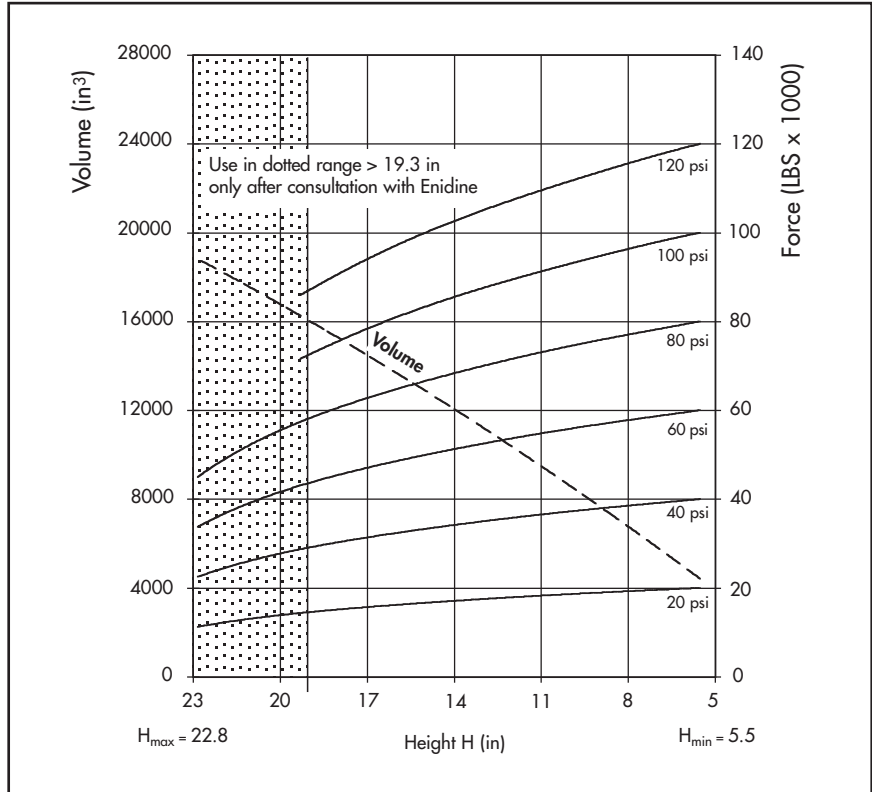
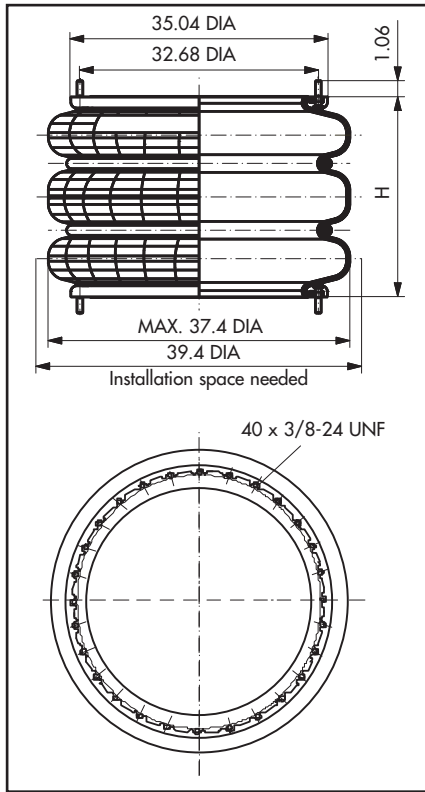

Purchase Order Data

Type	Part Number
Bellows with bead rings, 1 7/8 bolts, nuts and washers	YI-FT 5450-44-603
Rubber bellows only	YR-FT 5450-44-023

Additional types on request

Service Instruction:
3/8-24 UNF = 28-32 FT-LBS

Technical Data

Min. Pressure	0 psi
Return Force to min. height	≤ 380 lbs
Overall weight with bead rings, bolts, nuts and washers	97 lbs

Pneumatic Application - static characteristic values

Force F (lbs)

Pressure p (psi)	20	40	60	80	100	120	Vol. (in³)
Height H (in)	18	15080	30170	45250	60340	75420	15381
	16	16190	32380	48560	64750	80940	13705
	14	17090	34190	51280	68380	85470	12000
	12	17880	35770	53650	71530	89410	10289
	10	18590	37170	55760	74340	92930	8564
	8	19290	38590	57880	77180	96470	6810
	6	19850	39700	59550	79390	99240	4893



Applications:

- Oil Exploration
- Foundries
- Bottling Equipment
- Valve Mfg
- Logging Industry
- Rubber Industry
- Amusement Rides
- Food Packaging
- Scissors Lift Manufacturing
- Glass Manufacturing (Plate Glass)
- Sewage Processing Equipment





ENGINEERED FOR LIFE

ITT Endine Inc.
7 Centre Drive
Orchard Park, New York 14127
Phone: 716-662-1900
Fax: 716-667-1385
Email: industrialsales@itt.com
www.itt-infrastructure.com
www.endine.com